

SYNGENE INTERNATIONAL LTD, VELANKANI TECH PARK, ACCESSIBILITY AUDIT REPORT

PREPARED BY SVADHIN SOLUTIONS

DISCLAIMER.....	2
EXECUTIVE SUMMARY	3
SECTION 1: AUDIT OVERVIEW.....	4
AUDITORS	4
SCOPE OF THE AUDIT	4
ACCESSIBILITY AUDIT OBJECTIVES.....	4
INDIAN LEGISLATION ON ACCESSIBLE ENVIRONMENT: RPWD ACT, 2016	4
NATIONAL BUILDING CODE 2016: ACCESSIBILITY	5
SECTION 2: FLOOR ACCESSIBILITY OVERVIEW	6
GROUND FLOOR, SYNGENE INTERNATIONAL, VTPL – ACCESSIBILITY OVERVIEW	8
FIRST FLOOR, SYNGENE INTERNATIONAL, VTPL – ACCESSIBILITY OVERVIEW	10
SECOND FLOOR, SYNGENE INTERNATIONAL, VTPL – ACCESSIBILITY OVERVIEW.....	12
THIRD FLOOR, SYNGENE INTERNATIONAL, VTPL – ACCESSIBILITY OVERVIEW	14
SECTION 3: INACCESSIBLE AND NON-COMPLIANT BARRIERS.....	16
SECTION A – KEY ACCESS POINTS.....	16
SECTION B – WORK ACCESS	38
SECTION C – FACILITIES	58
SECTION D – EMERGENCY EVACUATION FACILITIES	84
SECTION 4: RECOMMENDATIONS TO OVERCOME INACCESSIBILITY	91
APPENDIX 1: SVADHIN SOLUTIONS COMPANY PROFILE.....	98
APPENDIX 2: GUIDELINES FOR ACCESSIBILITY	99
APPENDIX 3: GLOSSARY OF TERMS	104

DISCLAIMER

This accessibility audit report outlines findings, barriers to accessibility and recommendations specifically for Syngene's office in Syngene International Limited, Velankani Tech Park, 43, Hosur Rd, Electronics City Phase 1, Electronic City, Bengaluru, Karnataka 560100, as found during the site audit which was conducted on 9th and 10th March, 2023. This audit report does not include details for areas and job settings where entry and the audit process were restricted and data (including images) were filtered owing to confidentiality. Please note that all the recommendations and solutions suggested in this report are strictly the opinions of the auditors and based on the specific accessibility barriers noted at the site and have no bearing to any other site or the same site at any other point of time. The findings and recommendations shared by Svadhin Solutions are keeping in mind the Indian Accessibility standards and other American and European Accessibility standards that the Indian guidelines are derived from. While, the observations and findings include activities of people and organization protocols apart from building and space design audit, the findings and recommendations are only pertaining to the access of the physical environment and do not look into other deeper management processes. The solutions recommended by the auditors are product integrations, design and structural changes and maintenance requirements to make the space accessible but don't take the responsibility of actual execution of the shared solution by other parties. Please note that this report is the intellectual property of Svadhin Solutions and solely meant for the client to identify, understand and implement for accessibility for the specific facility as referred to in the report. The report holds sensitive and confidential information and is meant only for the eyes of the client and not for anyone else's or for any other commercial pursuit.

EXECUTIVE SUMMARY

Inaccessibility is not an individual's shortcoming but that of the environment, be it physical, digital, cultural, or social. Therefore, accessibility cannot be an oversight or an aspect of sympathy; instead, it should be treated as an essential. Inclusive design can bring forward access to resources that have been unexplored and under-utilized till now. With the mandates provided by the RPwD Act, 2016, and the positive initiative by corporates including Syngene International Limited, the accessibility gap in the social and economic fabric can be overcome.

The following report is an audit summary outlining the findings and solutions to overcome the accessibility barriers for Syngene's office in Syngene International Limited, Velankani Tech Park, 43, Hosur Rd, Electronics City Phase 1, Electronic City, Bengaluru, Karnataka 560100, initiated by Syngene and Enable India Solutions and conducted by Svadhin Solutions. The field review of the accessibility audit was conducted on 9th and 10th March, 2023 by Poonacha CC and Ponnanna PK post which the audit analysis and summary was undertaken by Natya T and Poonacha CC. This assessment and survey report is intended to not only identify barriers to access, but to provide solutions as well to support Syngene in transforming their office into a compliant and accessible workspace and facility.

The summary of the findings is presented in a floor layout overview and area-by-area accessibility markers as well as in detailed observations on the barriers to aid the organization in taking necessary actions. The area-by-area accessibility marker table gives an overview of accessibility status for the different PwD users with respect to the specific areas in the floor, and the floor layout overview visually indicates the bottlenecks in floor accessibility. The floor layout overview does not include the vision impairment (VI) users' barriers to accessibility. Post this the detailed findings have been shared under the sub-headings of Access; Work Access; Other Facilities; and, Emergency Evacuation Facilities to help build an overall picture of access to key activities while at work. The Syngene's office is inaccessible for people with visual impairment (VI), mostly inaccessible for wheelchair users and partially inaccessible for people with other physical disabilities (PD) and mostly accessible for speech and hearing impairment (SI, HI) users. Solutions have been prioritized based on urgency in their relative importance to access to work, as well as compliance as per the RPWD Act, 2016. These solutions have also been marked in cost categories to support the execution team at Syngene's office to take informed decisions and smoothen the process of accessibility transition of the facility.

SECTION 1: AUDIT OVERVIEW

AUDITORS

NATYA T

POONACHA CC

SITE AUDIT TEAM

POONACHA CC

PONNANNA PK

SCOPE OF THE AUDIT

This accessibility audit for Syngene's office in Velankani Technology Park covered the built environment, access to various facilities and protocols critical to access, independence, safety, and performance in a work environment for persons with disabilities.

ACCESSIBILITY AUDIT OBJECTIVES

The general objective of the Syngene's office's accessibility audit was to identify the overall accessibility status of the office working floors, accessibility status of key facilities, compliance of accessible building norms and share reasonable measures and suggestions to the management of Syngene to ensure the full inclusion of persons with disabilities. Specific objectives of the accessibility audit were:

- To assess whether PwDs are able to access the building with ease
- To assess whether PwDs can access the different work spaces with ease
- To gauge the ease with which PwDs can circulate vertically and horizontally within the premises
- To evaluate the usability of the facilities provided for persons with disabilities
- To assess measures and setups put in place by the Syngene's office administration for PwDs to evacuate during an emergency

INDIAN LEGISLATION ON ACCESSIBLE ENVIRONMENT: RPwD ACT, 2016

The Rights of Persons with Disabilities Act, 2016 is very clear on accessibility of the built environment for PwDs. A really important development under this Act is that it requires mandatory conformance to accessibility standards and recognizes that reasonable accommodation and universal design are critical for facilitating access in an equitable manner and creating an accessible framework for India going forward. Specifically, Section 45 elaborates on conformance for all existing public buildings (1) All existing public buildings shall be made

accessible in accordance with the rules formulated by the Central Government within a period not exceeding five years from the date of notification of such rules:” while, Section 44 explicates how new buildings must adhere to the accessibility guidelines -(1) No establishment shall be granted permission to build any structure if the building plan does not adhere to the rules formulated by the Central Government.













The Act defines “reasonable accommodation” as “necessary and appropriate modification and adjustments, without imposing a disproportionate or undue burden in a particular case, to ensure to persons with disabilities the enjoyment or exercise of rights equally with others.” And, defines “public building” means a Government or private building, used or accessed by the public at large, including a building used for educational or vocational purposes, workplace, commercial activities, public utilities, religious, cultural, leisure or recreational activities, medical or health services, law enforcement agencies, reformatories or judicial for a railway stations or platforms, roadways bus stands or terminus, airports or waterways; For further details refer to the PwD Act, 2016.





NATIONAL BUILDING CODE 2016: ACCESSIBILITY

The National Building Code of India (NBC) is a comprehensive building code providing guidelines for regulating the building construction activities across the country. It serves as a model code for adoption by all agencies involved in building construction works; be it, the Public Works Departments, other government construction departments, local bodies or private construction agencies. The accessibility chapter was integrated as an addition to the NBC 2016 to improve the building design codes and can be found in Volume 1, Part 3 Development Control Rules and General Building Requirements and Annex B of Part 3.

SECTION 2: FLOOR ACCESSIBILITY OVERVIEW

The floor layouts mark areas of concern that include inaccessible area, point, entry, or circulation path and non-compliant areas. The following layout overviews cover accessibility barriers mostly pertaining to wheelchair users and people with other physical disabilities and do not completely include accessibility for Visual Impairment (VI), Speech Impairment (SI) and Hearing Impairment (HI) users, instead the same will be discussed only in specific sections where it is relevant. The floor layouts and the tables are shared to give a bird's eye view of the accessibility barriers and therefore don't share the depth and the details of all the barriers. Shared below is the key of symbols used for mapping the accessibility status for each floor of the building in the floor layouts and accessibility for each room/area in a floor specifically for different PwD users in the tables along with the rules taken into consideration for the markings on the floor layouts.





KEY OF SYMBOLS - LAYOUTS			KEY OF SYMBOLS - TABLES	
	Inaccessible Circulation Path	> 762 mm path width		Wheelchair User & People with Physical Disabilities
	Non-Compliant Circulation Path	< 762 mm but > 900 mm path width for passages between desks & >1500 mm path width for evacuation routes/main passages		Vision Impairment
	Practically Hard to Navigate Circulation Path	< 900 mm but > 1200 mm path width		Speech Impairment
	Inaccessible Area	Navigation path width inside the meeting rooms below > 762 mm Or Have Inaccessible Features		Hearing Impairment
	Non-Compliant Area	Navigation path width inside the meeting rooms below > 1200 mm Or Have Non-Compliant Features		Not Accessible
	Changed Layout	-		Non-Compliant

	Inaccessible Point	-		Accessible
	Non-Compliant Point	-		
	Inaccessible entry	Entries with high door tension and/or lack of door clearance, and/or inaccessible door width, and/or inaccessible door handle types		
	Non-Compliant entry	Entries with non-compliant door width, and/or non-compliant vision panels		
RE	Restricted Entry			

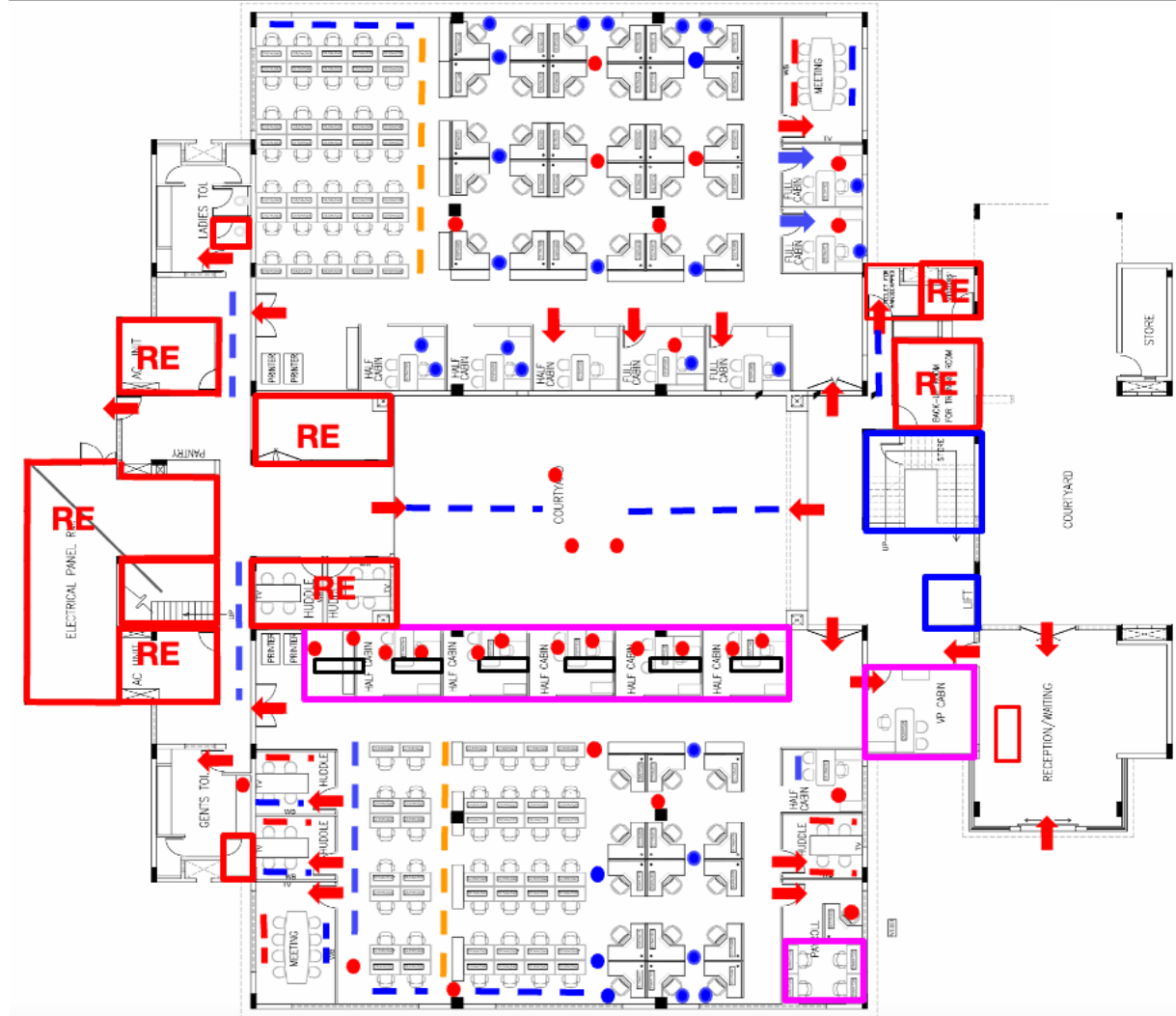
GROUND FLOOR, SYNGENE INTERNATIONAL, VTPL – ACCESSIBILITY OVERVIEW

GROUND FLOOR, SYNGENE INTERNATIONAL LTD, VTPL





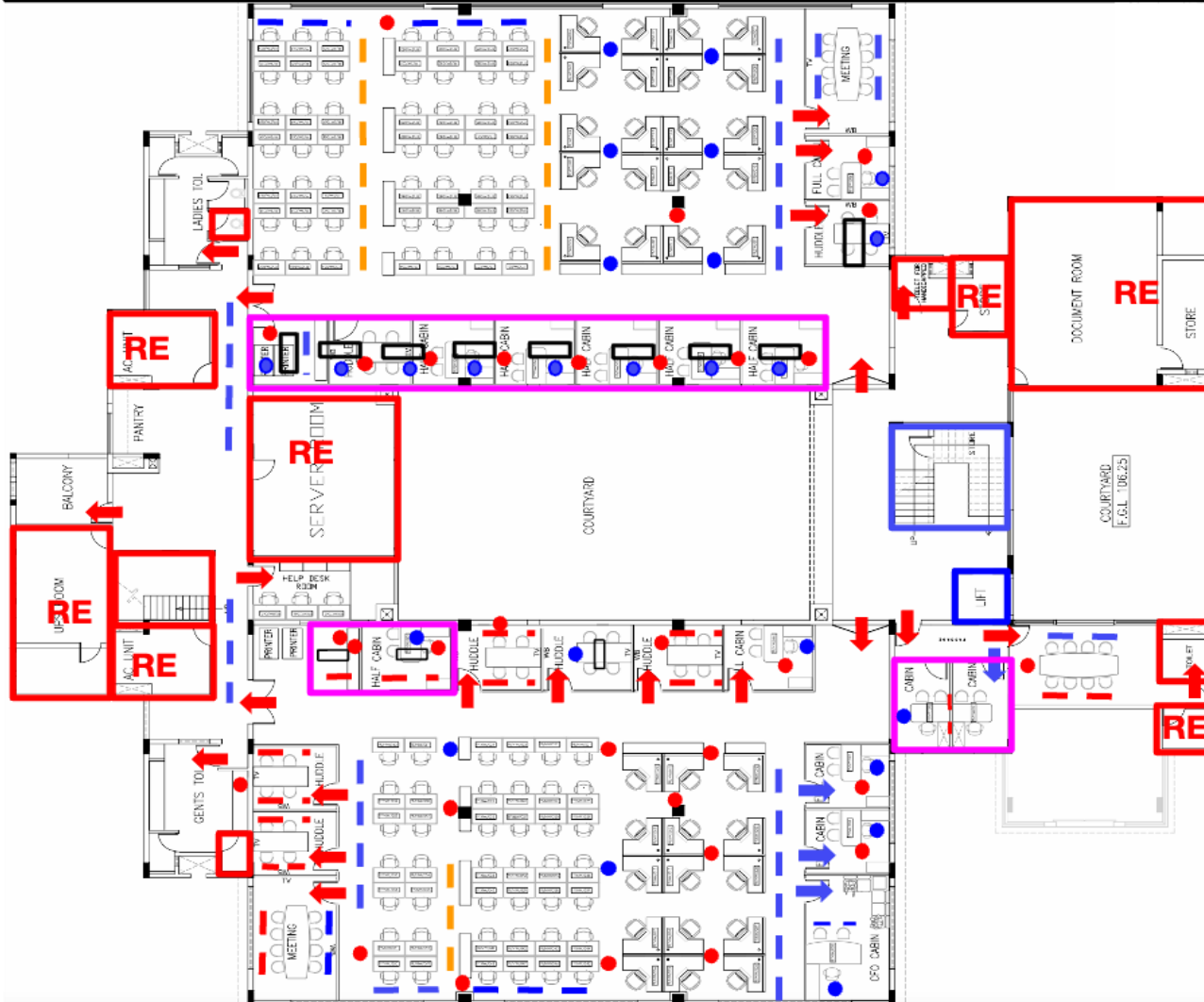

AREAS				
BUILDING MAIN ENTRANCES	□/X	X	✓	✓
RECEPTION	X	X	□	□
PERSONAL CABINS	X	X	✓	✓
CONFERENCE ROOMS	X	X	✓	□
MEETING ROOMS	X	X	✓	✓
COURTYARD	X	X	✓	✓
PANTRY	X	X	✓	✓
PWD RESTROOM	X	X	✓	□
MEN'S & WOMEN'S RESTROOMS	-/X	X	✓	□
MAIN LIFT & LIFT LOBBY	□	X	✓	✓
STAIRCASES	□/X	X	✓	✓
EMERGENCY EVACUATION ROUTES & EXITS	□	X	□	□

FIRST FLOOR, SYNGENE INTERNATIONAL, VTPL – ACCESSIBILITY OVERVIEW

FIRST FLOOR, SYNGENE INTERNATIONAL LTD, VTPL





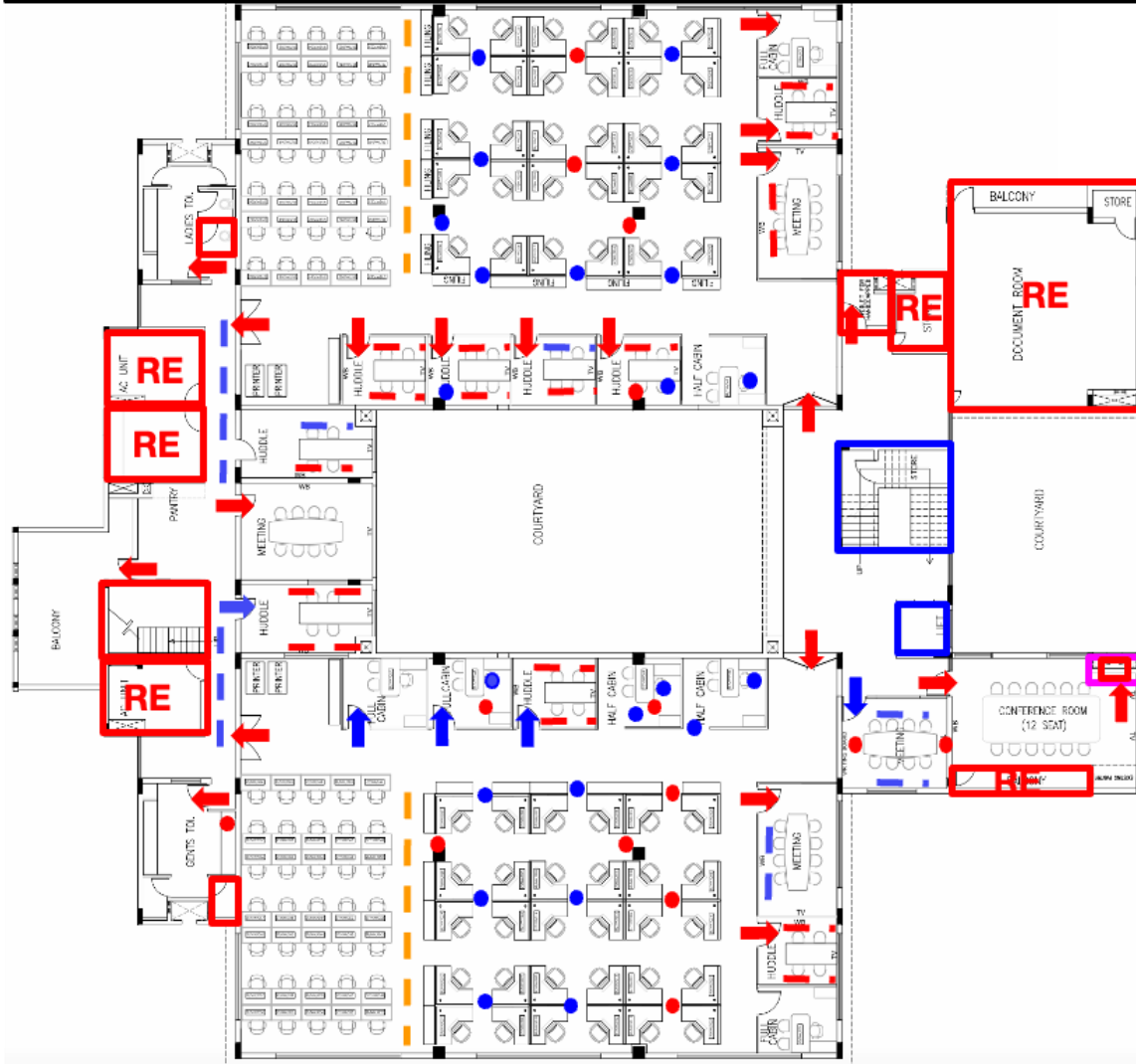

AREAS				
IT HELP DESK	X	X	✓	✓
PERSONAL CABINS	X	X	✓	✓
CONFERENCE ROOMS	X	X	✓	□
MEETING ROOMS	X	X	✓	✓
BALCONY	X	X	✓	✓
PANTRY	X	X	✓	✓
PWD RESTROOM	X	X	✓	□
MEN'S & WOMEN'S RESTROOMS	-/X	X	✓	□
MAIN LIFT & LIFT LOBBY	□	X	✓	✓
STAIRCASES	□/X	X	✓	✓
EMERGENCY EVACUATION ROUTES & EXIT STAIRCASES	□	X	□	□

SECOND FLOOR, SYNGENE INTERNATIONAL, VTPL – ACCESSIBILITY OVERVIEW

SECOND FLOOR, SYNGENE INTERNATIONAL LTD, VTPL





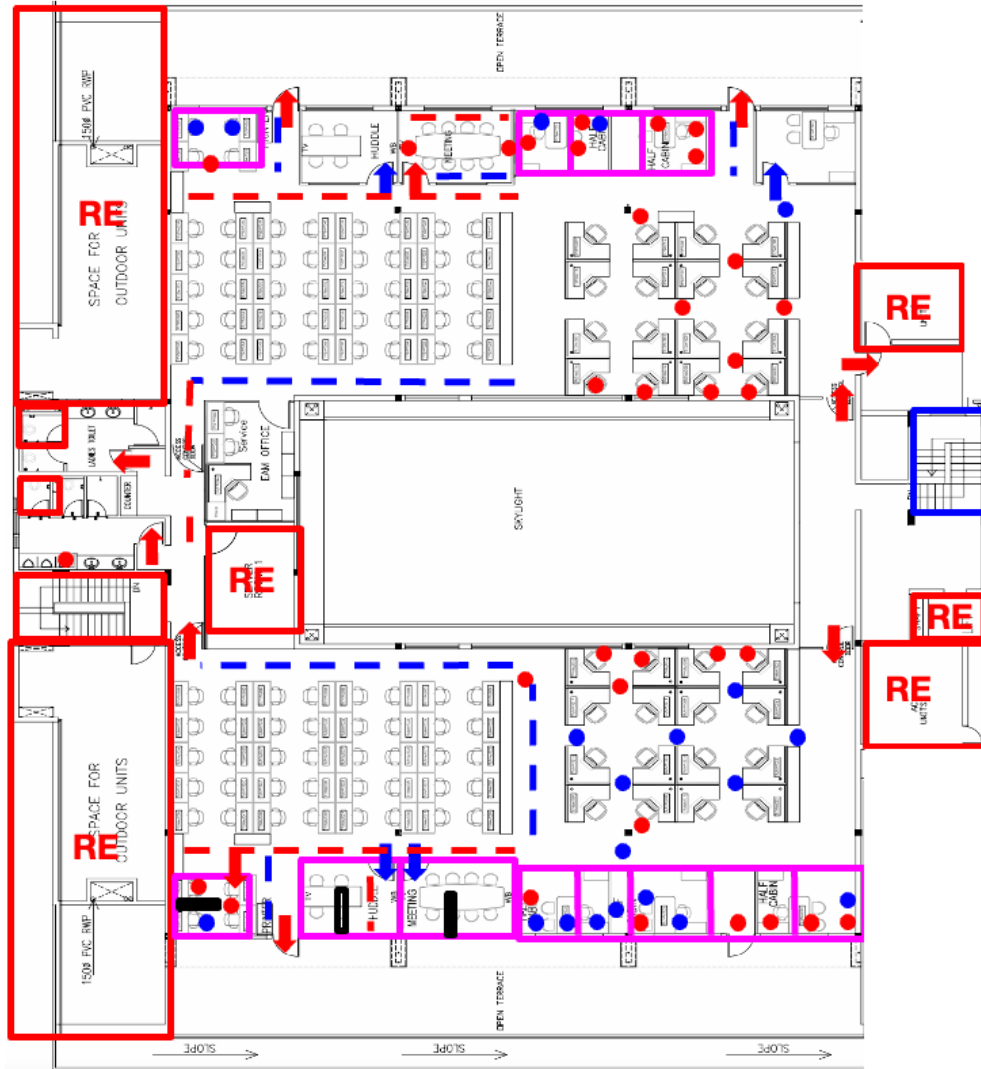

AREAS				
PERSONAL CABINS	X	X	✓	✓
CONFERENCE ROOMS	X	X	✓	□
MEETING ROOMS	X	X	✓	✓
BALCONY	X	X	✓	✓
PANTRY	X	X	✓	✓
PWD RESTROOM	X	X	✓	□
MEN'S & WOMEN'S RESTROOMS	-/X	X	✓	□
MAIN LIFT & LIFT LOBBY	□	X	✓	✓
STAIRCASES	□/X	X	✓	✓
EMERGENCY EVACUATION ROUTES & EXIT STAIRCASES	□	X	□	□

THIRD FLOOR, SYNGENE INTERNATIONAL, VTPL – ACCESSIBILITY OVERVIEW

THIRD FLOOR, SYNGENE INTERNATIONAL LTD, VTPL



AREAS				
PERSONAL CABINS	X	X	✓	✓
CONFERENCE ROOMS	X	X	✓	□
MEETING ROOMS	X	X	✓	✓
BALCONIES	X	X	✓	✓
PANTRY	X	X	✓	✓
MEN'S & WOMEN'S RESTROOMS	-/X	X	✓	□
MAIN LIFT & LIFT LOBBY	□	X	✓	✓
STAIRCASES	□/X	X	✓	✓
EMERGENCY EVACUATION ROUTES & EXIT STAIRCASES	□	X	□	□

SECTION 3: INACCESSIBLE AND NON-COMPLIANT BARRIERS

SECTION A – KEY ACCESS POINTS

CAMPUS MAIN ENTRANCES & EXITS



- There is no pedestrian pathway demarcated and kept at Gate 5 which would put PwD pedestrians walking into the campus at safety risk as they would be using the vehicular route
- The speed breaker in front of the Gate 5 in the pedestrian walkway makes this route harder to navigate for certain PwDs making this entry gate non-compliant
- The Gate 5 security sign in counter access is at step level and does not have provision for an accessible ramp, step height is non-compliant and hard to use by most PwDs and does not have any handrails for support making this entry inaccessible and non-compliant for PwDs
- The height of the security sign-in counter at Gate 5 is inaccessible for wheelchair users and certain other PwDs
- There is no dedicated walkway leading from Gate 5 to the building entrance making this route non-compliant and unsafe for PwD movement
- Gate 6 pedestrian exit path has no dedicated walkway and has uneven surface making it non-compliant and unsafe for certain PwDs
- The turning space after the Gate 6 pedestrian exit gate is non-compliant and will be hard for certain wheelchair users to use
- Gate 6 security booth is at a step level does not have a provision for an accessible ramp making entry to this security booth non-compliant and inaccessible for wheelchair users
- Gate 6 security booth is at a step level and the entry steps have no handrails, antiskid markings on the step treads and a clear landing space from the steps to the entry door making this inaccessible and non-compliant for certain PwDs

		<ul style="list-style-type: none"> ➤ Gate 6 security booth entry door has inaccessible push and pull side door clearances, handles placed at inaccessible heights with no colour contrast against the door frame, and there is no provision for an accessible signage making this entry non-compliant for PwDs
		<ul style="list-style-type: none"> ➤ Gate 2 pedestrian entry has a step level access without provisions for an accessible ramp making this entry non-compliant and inaccessible for wheelchair users and certain other PwDs
		<ul style="list-style-type: none"> ➤ The path leading to the security sign in counter at Gate 2 has a level deference making it unsafe for certain PwDs
		<ul style="list-style-type: none"> ➤ The security reception/sign in counter at Gate 2 are at an inaccessible height, it does not have dual level counters with a lower counter having knee clearance and lacks accessible identification signage making this counter non-compliant and inaccessible for PwDs
		<ul style="list-style-type: none"> ➤ The visitors waiting lounge at Gate 2 has non-compliant door width, handles placed at inaccessible height and does not have contrast against the door frame, door doesn't contrast against the background, no push side door clearance and no provision for an accessible signage making this entry inaccessible and non-compliant for PwDs
		<ul style="list-style-type: none"> ➤ The water dispenser placement in Gate 2's visitors waiting lounge makes it non-compliant and inaccessible for certain PwDs
		<ul style="list-style-type: none"> ➤ The light switches in the Gate 2 visitors waiting lounge are placed at a non-compliant height and do not contrast against the back ground making them non-compliant for certain PwDs
		<ul style="list-style-type: none"> ➤ Most of the identification and directional signages at the gates and along the campus pathway are placed at non-compliant and inaccessible heights and none of them have provisions for braille and tactile making them non-compliant and inaccessible for PwDs
		<ul style="list-style-type: none"> ➤ All the three campus entry/exit gates lack clear directional signage leading to the Syngene building making navigation non-compliant and inaccessible to PwDs

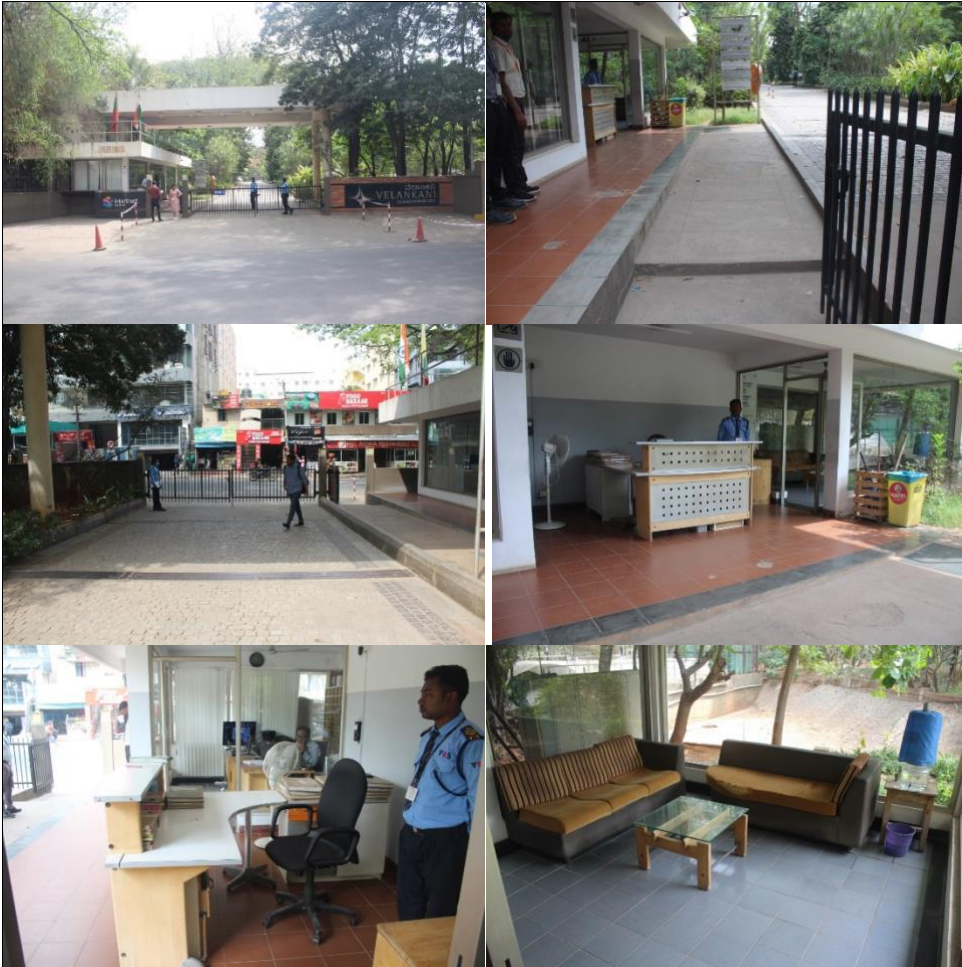

- There is no continuously running footpath leading from Gate 2 to the building entrance and the walkways have uneven surface making this route non-compliant and unsafe for PwD movement
- There are no tactile pictographic maps placed at the different gates as required by compliance to support people with visual impairment to navigate around the campus to reach their destinations
- There are no assistance protocols in place to support PwDs including how to interact with people with different disabilities as well as training in sign language to support people with hearing impairment
- Gratings around the campus pedestrian routes have non-compliant opening widths and can be safe for PwDs using mobility aids





Result: Campus Main Entrances & Exits are Non-Compliant and Partially Inaccessible

BUILDING MAIN ENTRANCES & EXITS

- | | |
|--|--|
| | <ul style="list-style-type: none"> ➤ Entry route to the main building from Gate 2 has flights of steps leading to it without an accessible egress route making this route and entry door inaccessible for wheelchair users ➤ Entry route to the main building from Gate 2 have gratings along the path with non-compliant openings making this non-compliant and unsafe for people using mobility aids |
|--|--|



- Flights of steps to the building main entrance connecting from Gate 2 have handrails placed at non-compliant heights without extensions, no colour markings on each of the step treads and no signage making this entry route steps non-compliant and unsafe for PwDs other than wheelchair users
- Entry route to the main building from Gate 5 via the parking lot has an inaccessible ramp with inaccessible gradient, missing mid-landings, no continuously running dual level handrails on both sides with extensions, no edge protection, handrails placed at non-compliant heights, and the shape of the handrail is of inaccessible type making this ramp inaccessible and non-compliant for PwDs
- The path leading from the ramp to the building main entrance has uneven surface at certain parts making this route unsafe for PwDs
- Both the building entry/exit doors have high door tension, handles placed at inaccessible heights, no dual level colour bands on the glass panels and the doors, door frames that are not distinguishable from the surrounding glass wall panels and no provisions for accessible signage placed at accessible heights with braille and tactile making these entries/exits non-compliant and inaccessible for PwDs
- The loose mats at both the main entrance doors can be unsafe for PwDs and are non-compliant



Result: Building Main Entrances are Non-Compliant and Partially Inaccessible

RECEPTION



- The reception has an inaccessible counter which does not have dual level counters with an accessible lower level counter having knee clearance for wheelchair users and people with dwarfism and lacks an accessible identification signage making this counter non-compliant and inaccessible for PwDs
- The storage cabinets under the reception table have non-compliant type of handles and lack braille and tactile labels making them non-compliant and inaccessible for certain PwDs
- There is no loop induction unit and a tactile pictographic map placed at the reception as required by compliance to support people with hearing impairment and people with visual impairment respectively
- There are no assistance protocols in place to support PwDs including how to interact with people with different disabilities as well as training in sign language to support people with hearing impairment
- There are no directional signage with provisions for braille and tactile to guide people from the reception to other areas in the office floors as per compliance
- The water dispenser in the reception area is placed at a non-compliant height and the drip bucket placed in front of the water dispenser will making it inaccessible for wheelchair users to access and use it
- The water dispenser in the reception area has an inaccessible hot water button type making it inaccessible for people with hand impairment and harder for other PwDs to use
- The floor entry door in the reception area has high door tension, inaccessible pull side door clearance, door handles placed at non-compliant to inaccessible height, there is no accessible identification signage with provisions for braille and tactile making this entry inaccessible and non-compliant for PwDs
- The access card readers and the PTRs at the floor entry door are placed at non-compliant to inaccessible heights and they do not have provisions for braille and tactile identification labels making them non-compliant and inaccessible for people with visual impairment



- The loose mats placed in the reception area can be unsafe for PwDs and are non-compliant
- Parts of the reception area flooring have high reflective index which can be disorienting for certain PwDs and is unsafe and non-compliant
- The instructional signage placed in the reception area is partially at non-compliant to inaccessible heights with no provisions for braille and tactile and/or audio out provisions making these signage inaccessible for people with visual impairment

Result: Reception is Non-Compliant and Inaccessible

LIFT & LIFT LOBBY (MAIN)



- There are no floor identification signage in all the three lift lobbies with provisions for braille and tactile making identification and navigation non-compliant and inaccessible for PwDs
- The emergency and safety instructions in all the three lift lobbies as well as inside the lift are placed at non-compliant and inaccessible heights with no provisions for braille and tactile making them non-compliant and inaccessible for PwDs
- The lift car has inaccessible door width and non-compliant internal dimensions making this lift car non-compliant and inaccessible for PwDs
- The lift call buttons are placed at inaccessible heights without provisions for braille making them non-compliant and inaccessible for PwDs
- There are no compliant type of handrails on all three sides inside the lift making the lift non-compliant and inaccessible for PwDs
- The control panel and emergency call button inside the lift are placed at inaccessible heights without provisions for braille making them non-compliant and inaccessible for PwDs



- The emergency phone inside the lift is placed at an inaccessible height and does not have an accessible identification signage making it non-compliant and inaccessible for PwDs
- The lift has no audio out to assist people with visual impairment making it inaccessible for them

Result: Lift & Lift Lobby (Main) is Non-Compliant and Partially Inaccessible

MAIN STAIRCASES



- Both the main staircases (front and back) have no floor identification signage on the staircase floor landings with provisions for braille and tactile making navigation challenging, non-compliant and inaccessible for PwDs
- Both the main staircases (front and back) have emergency instructional/directional signage placed at non-compliant and inaccessible heights without provisions for braille and tactile making them non-compliant and inaccessible for people with visual impairment and certain other PwDs
- The central running handrails of both the staircases (front and back) do not have handrail extensions at the top and bottom landings and the staircases are missing continuously running wall side handrails with extensions into the landings making both these staircases non-compliant and hard to use for certain PwDs

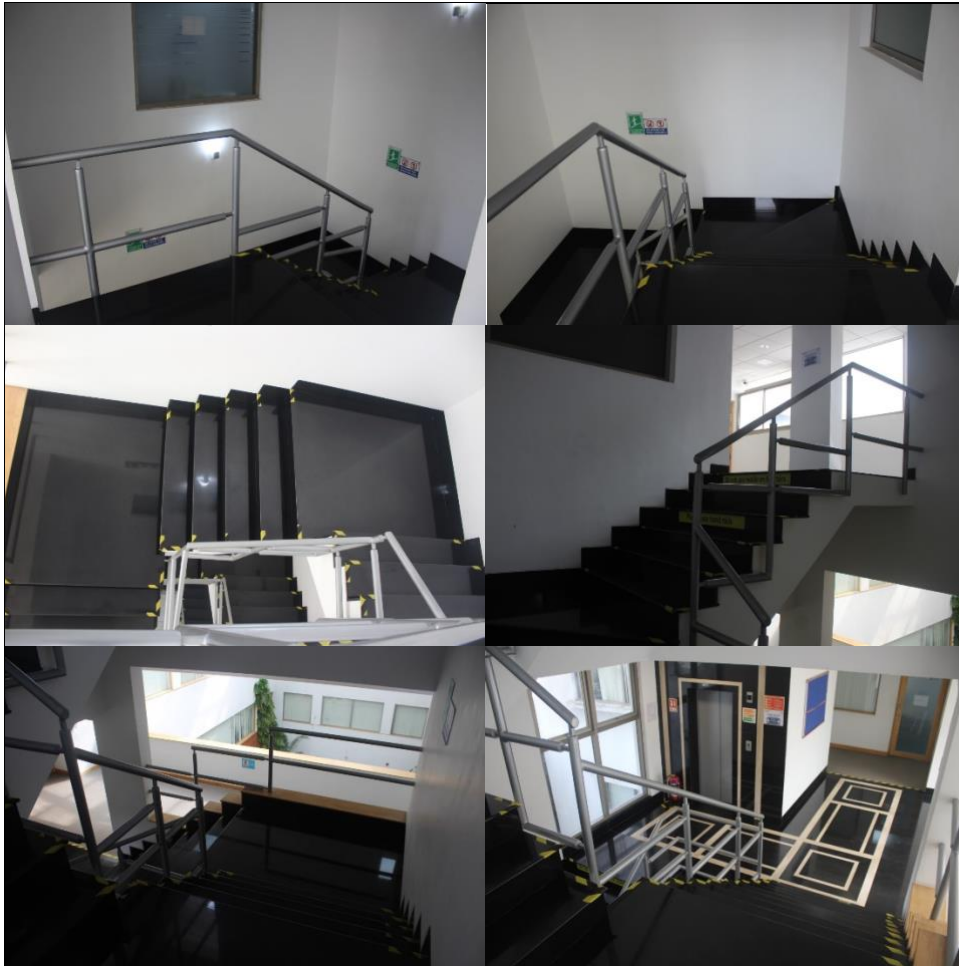

- The handrails are not completely accessible for people with visual impairment as they are lacking in braille markings for identification of the floor on each landing
- The front staircase handrails on the left side below the beam for the flight that is coming into the landing areas have inaccessible clearance from handrail to the beam making this part of the handrails possibly unsafe for certain PwDs and the head clearance non-compliant
- All the steps in both the staircases have non-compliant colour markings and there are no antiskid provisions for all the step treads making both the staircases non-compliant and unsafe for PwDs
- While, the back staircase width is inaccessible, the front staircase width is non-compliant when the wall-side handrails will be added and both the staircases have non-compliant staircase landing widths making them both non-compliant and inaccessible for PwDs
- Access to the front staircase from the third floor office entry has steps to access the staircase which don't have handrails and are missing anti-skid provisions for the step treads making them non-compliant
- The back staircase entry from the floor landings have small level differences because of the improperly flushed carpeted floors at certain points which may be unsafe for certain PwDs
- There is no identification signage marking the usage of the main staircase for everyday purposes

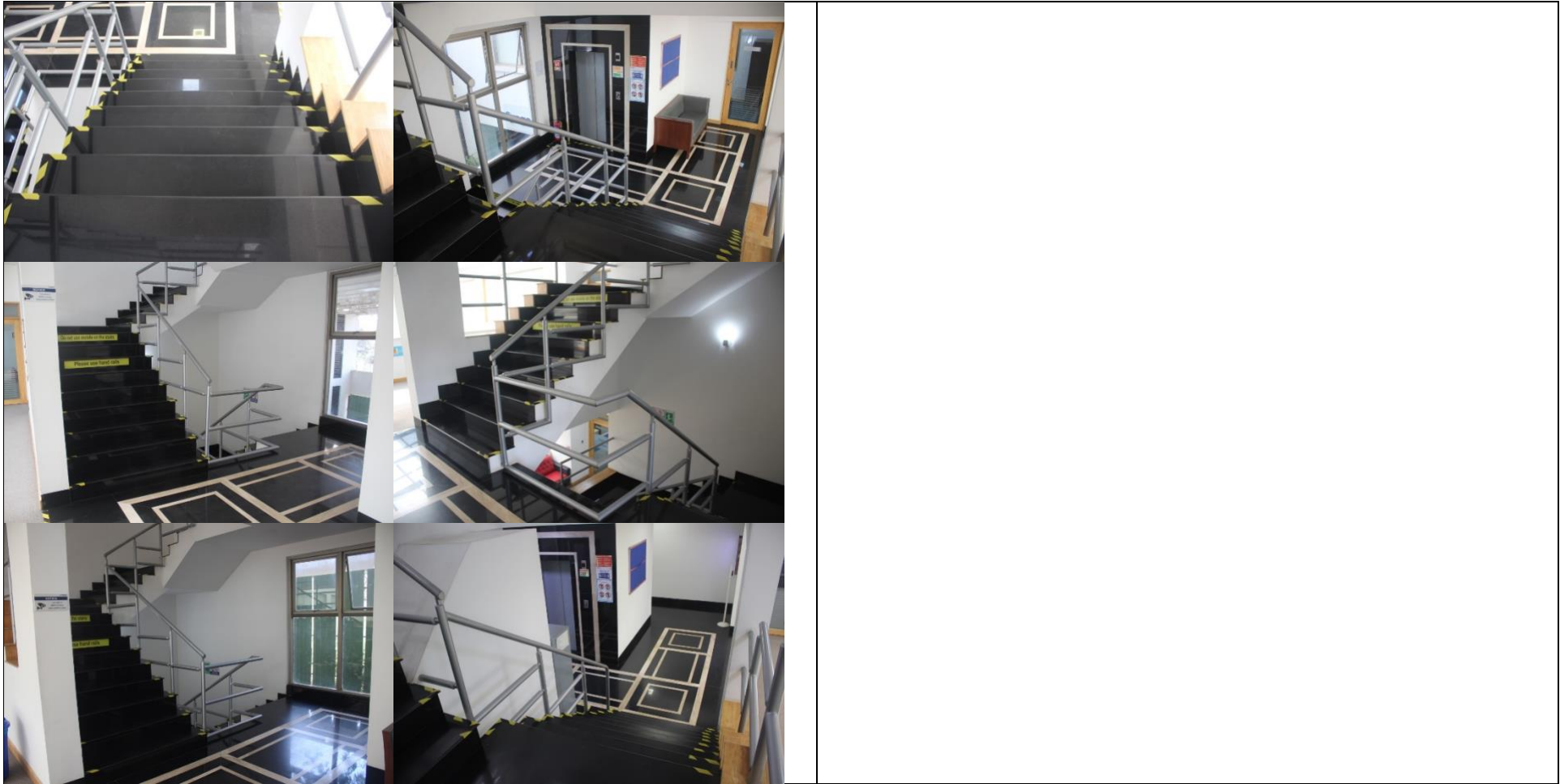

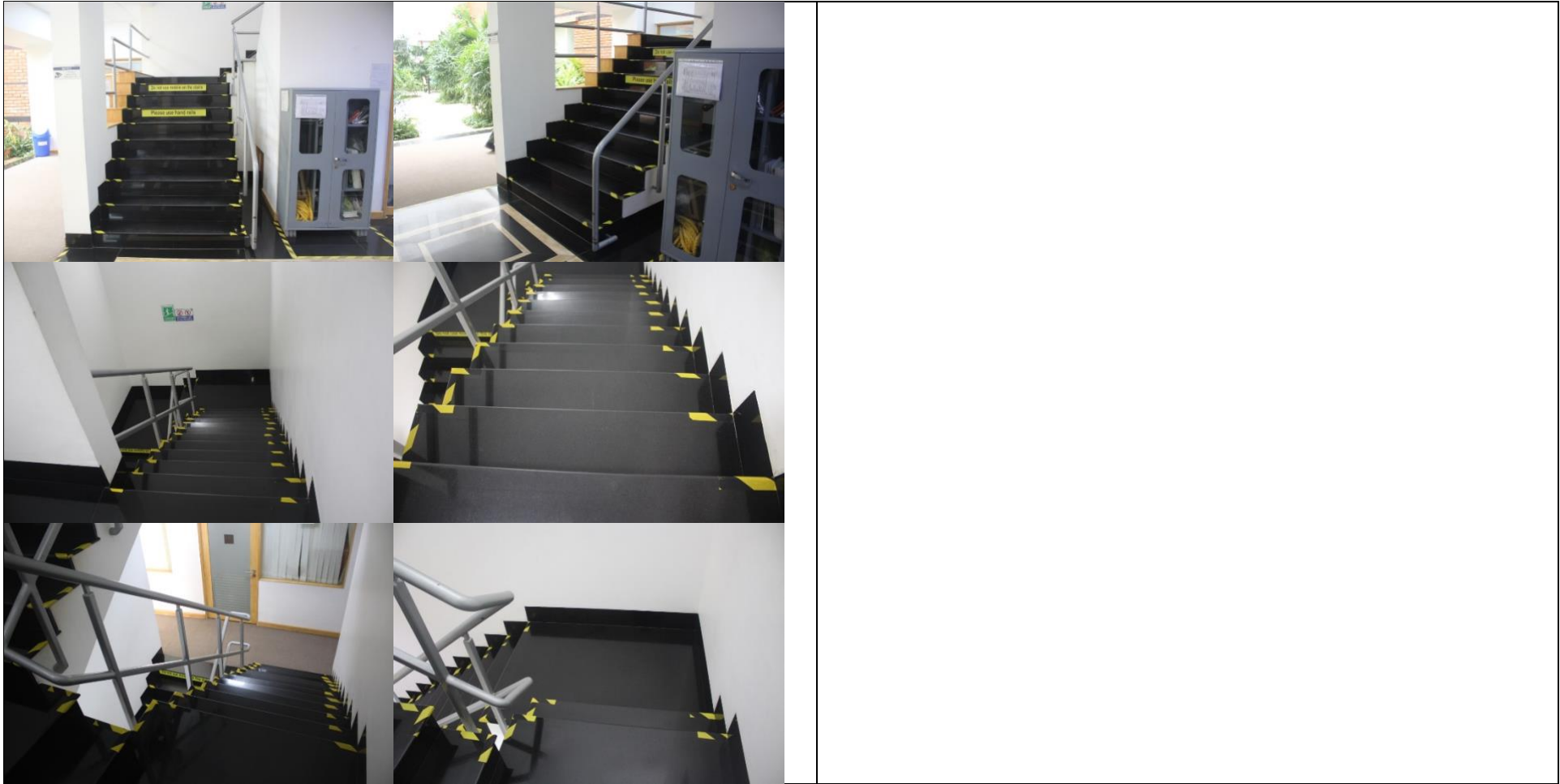



Result: Main Staircases are Non-Compliant and Partially Inaccessible

FLOOR ENTRANCES



- None of the floor entrance doors have an accessible identification signage with provisions for braille and tactile with strong colour contrast making them inaccessible and non-compliant
- All the floor entry doors have high door tension except for the floor entry door on third floor near the pantry and handles placed at inaccessible heights making them non-compliant and inaccessible for PwDs
- Both the third floor entry doors towards the toilet blocks have inaccessible pull side door clearances making them non-compliant and inaccessible for PwDs



- The access card readers and the PTRs placed next to all the floor entry doors are at non-compliant heights without any braille and tactile identification labels for people with visual impairment making them non-compliant
- All the fire alarms placed at the floor entry doors are at non-compliant heights and do not have provisions for braille and tactile making them non-compliant and inaccessible for certain PwDs
- The wall mounted hand sanitizers near all the floor entry doors are placed at inaccessible heights and act as projections making them inaccessible and unsafe for different PwDs
- All the first aid kits placed near the second and third floor entry doors are placed at inaccessible heights and do not have provisions for braille and tactile signage making them inaccessible for PwDs
- The fire extinguishers placed near the third floor entry doors towards the toilet blocks reduce the movement path at the door way
- None of the floor entry doors have kick plates as required by compliance
- All the floor entry doors have no accessible directional signage with provisions for braille and tactile making it difficult for PwDs to navigate from hereon

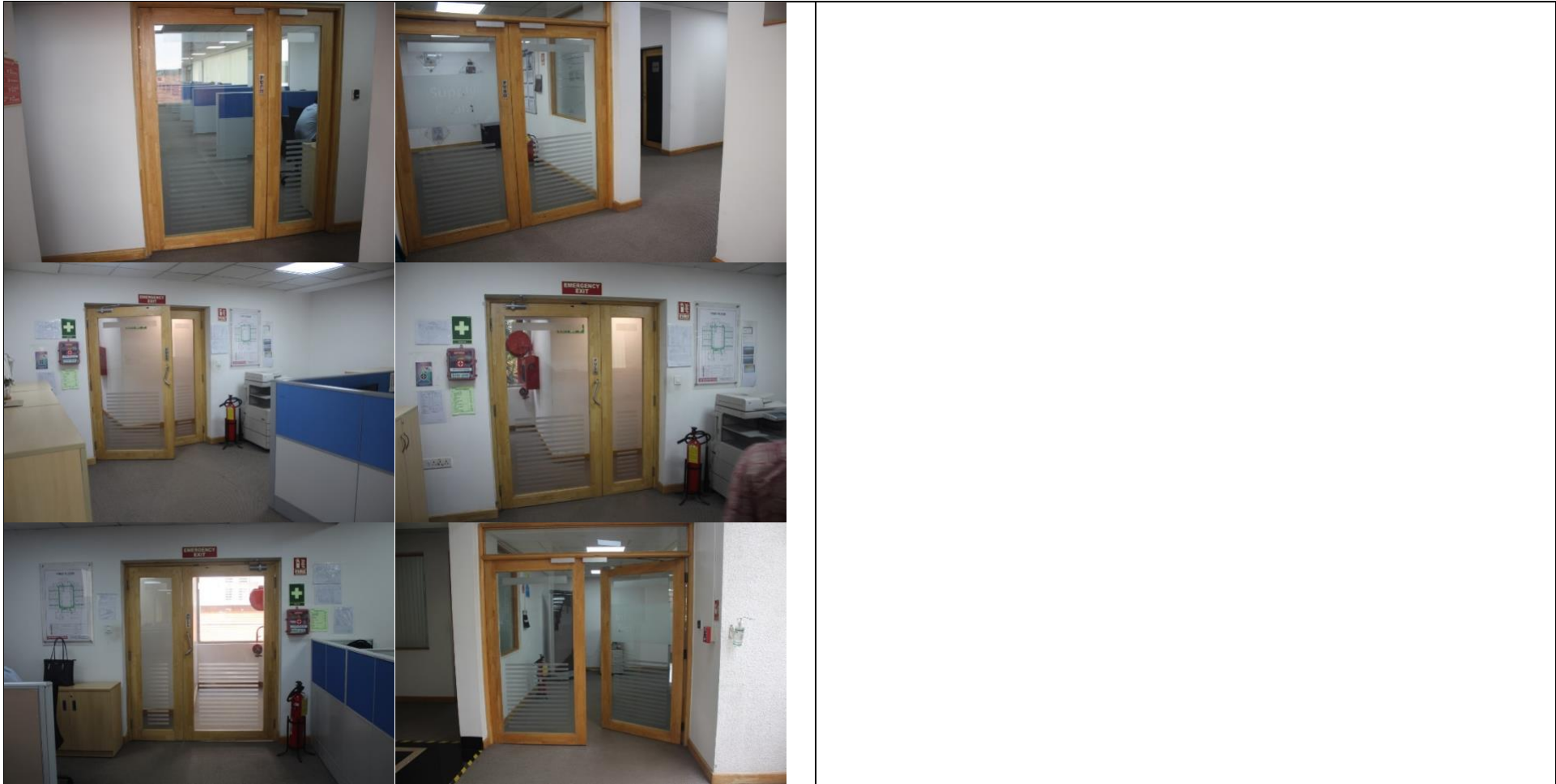

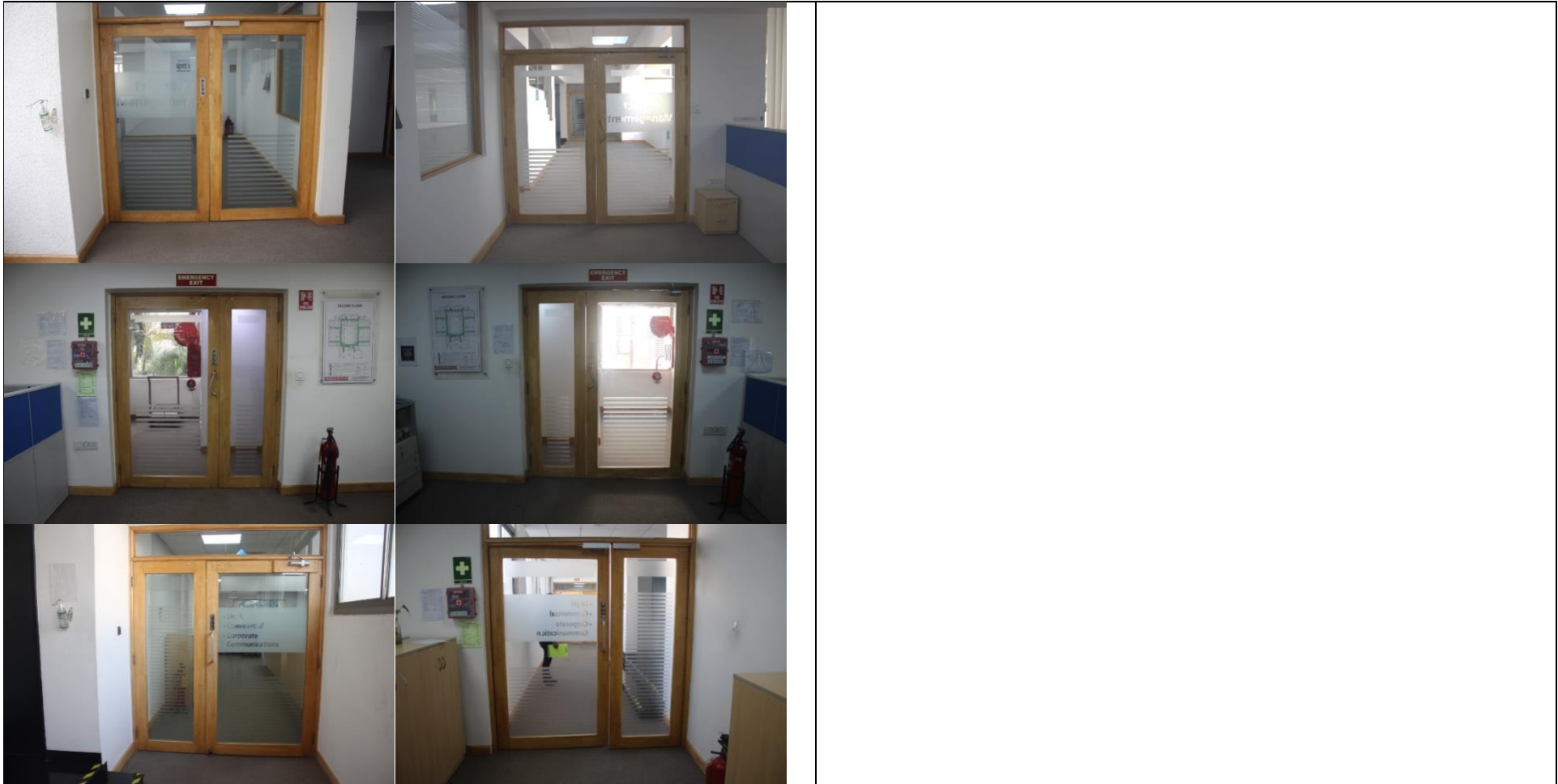

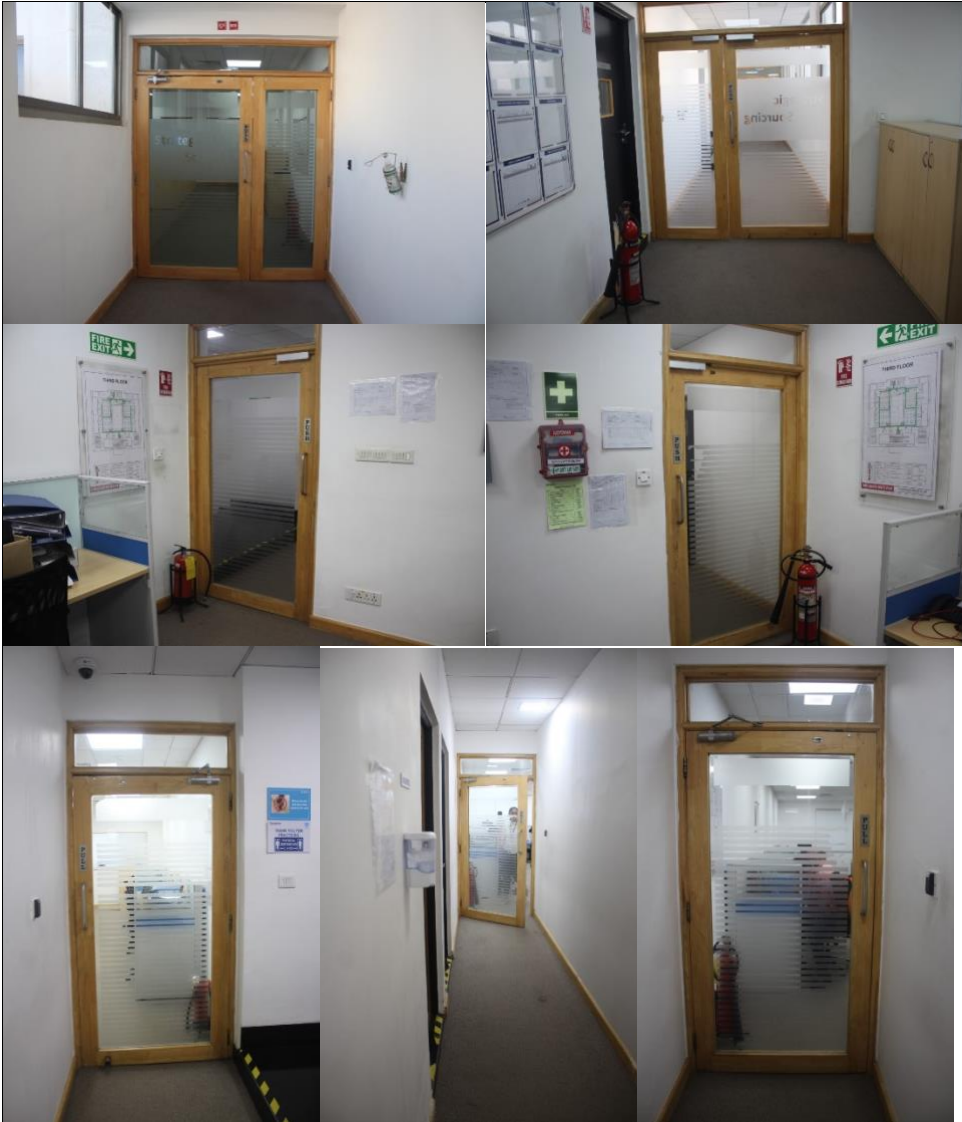

Result: Floor Entrances are Non-Compliant and Partially Inaccessible

GENERAL CIRCULATION AROUND THE FLOORS

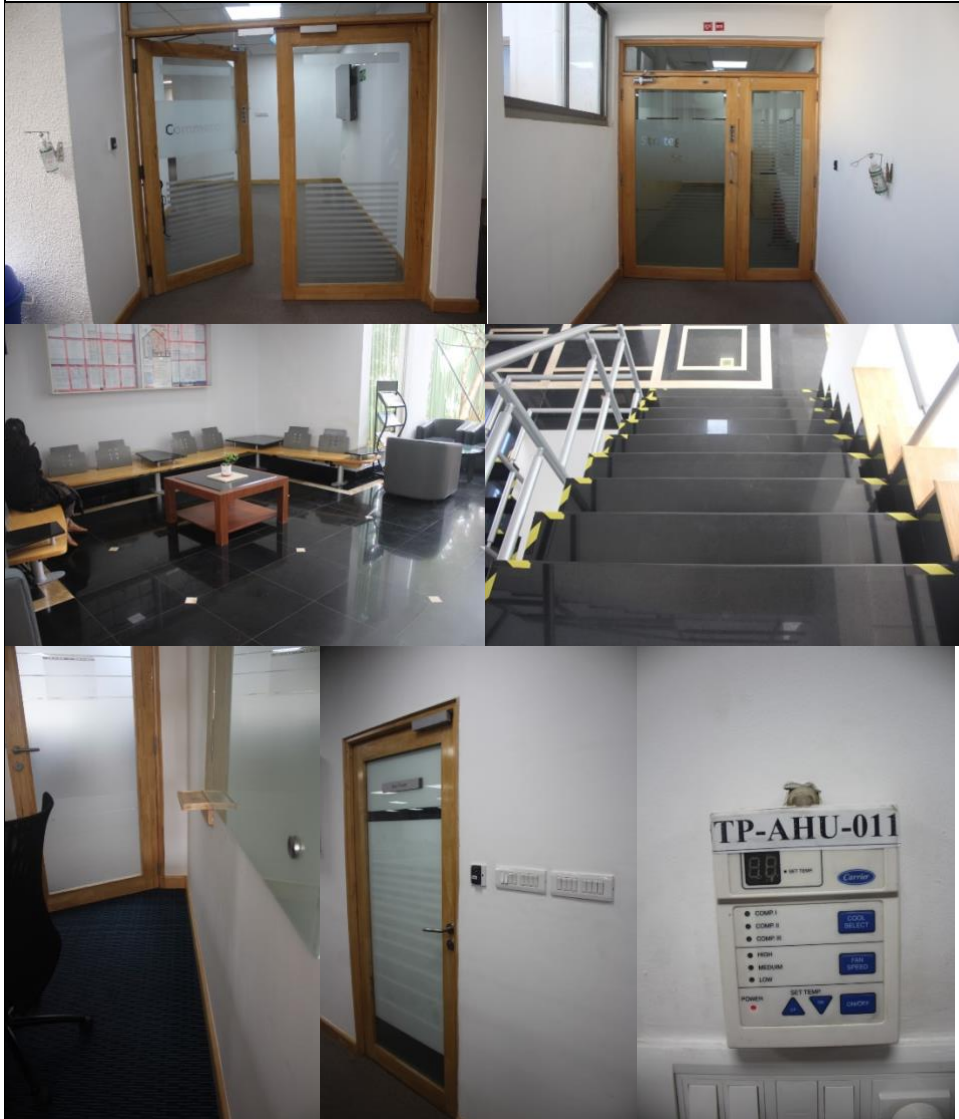

- None of the high usage doors like floor entry doors and the restroom doors have kick plates as required by compliance
- At certain areas like the reception, main staircase and the some parts of the lift lobby the flooring has high reflective index which gives out high glare and can be disorienting for PwDs making the flooring non-compliant and possibly unsafe for certain PwDs
- All the floor light switches and AC controls are placed at non-compliant heights and do not have the required contrast against the background wall making them non-compliant
- The wall mounted hand sanitizers are placed at inaccessible heights and act as projections making them inaccessible and unsafe for PwDs
- The access card readers and the PTRs placed next to all the floor entry doors are at non-compliant heights without any braille and tactile identification labels for people with visual impairment making them non-compliant
- All the fire alarms placed at the floor entry doors are at non-compliant heights and do not have provisions for braille and tactile making them non-compliant and inaccessible for certain PwDs
- All the marker holders in the conference and meeting rooms act as projections and can be unsafe for certain PwDs
- The workstation storage pedestals as well as storage cabinets are inaccessible for people with certain types of hand impairment because of the locking mechanism and handle type
- The workstation storage pedestals as well as storage cabinets need braille labels as when people with visual impairment are hired in those areas

Result: General Circulation Around the Office is Non-Compliant and Partially Inaccessible

SIGNAGE



- All existing signage (identification, directional and emergency evacuation signage) throughout the office floors do not have provisions for braille and tactile to support PwDs towards general navigation as well as during an emergency evacuation and are placed at non-compliant to inaccessible heights
- A lot of rooms and areas are missing identification signage completely which makes them hard to identify and navigate to
- None of the floor entrances have accessible signage to support navigation between areas
- There are no accessible signage indicating accessible facilities across the office
- Most of the informational/instructional signage are placed at non-compliant to inaccessible heights with no provisions for braille and tactile and/or audio out provisions making them inaccessible for people with visual impairment
- The accessible restroom signage have no clear content only a pictograph with no provisions for braille and tactile making them non-compliant and hard to read for certain PwDs

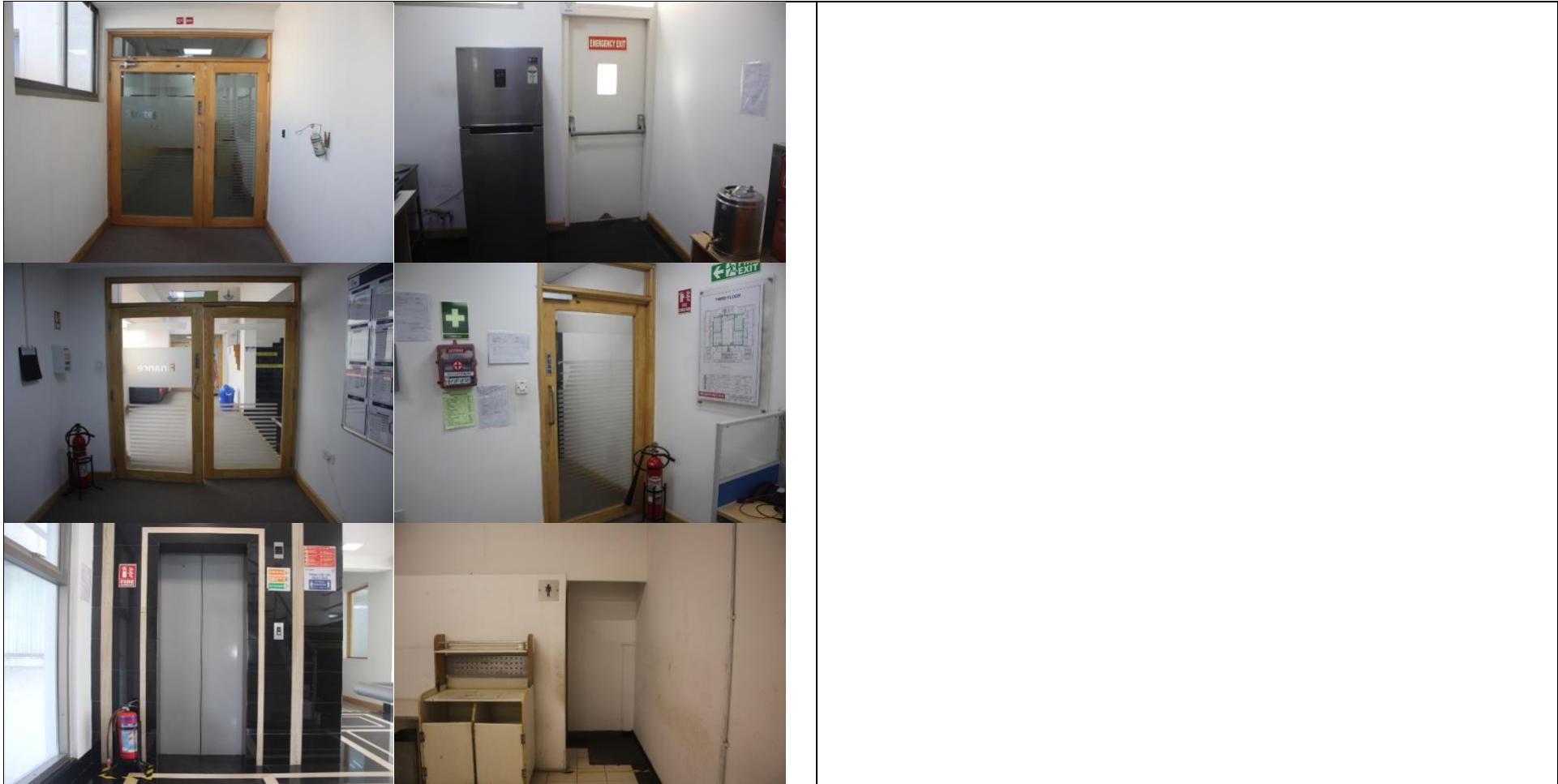

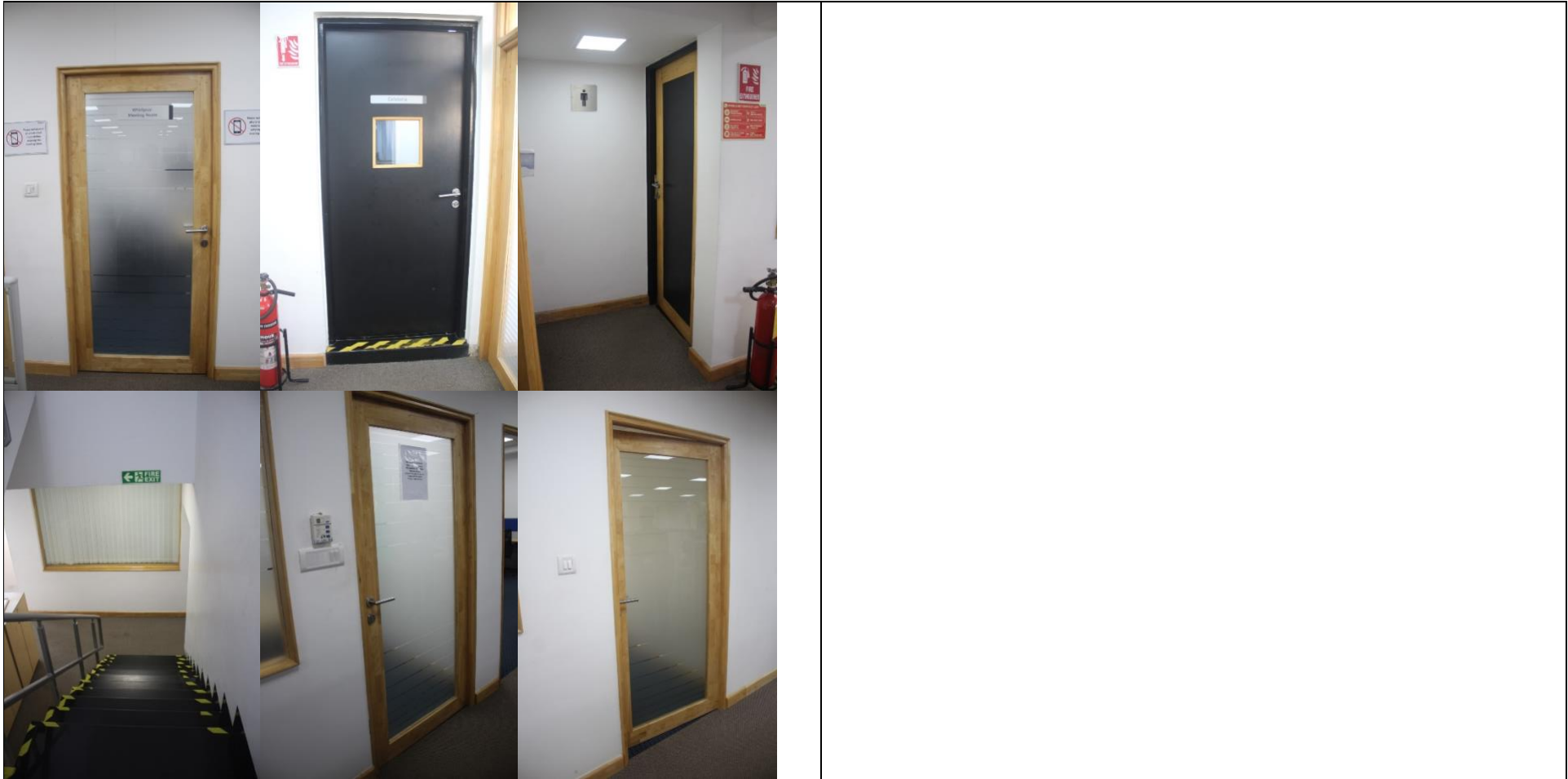

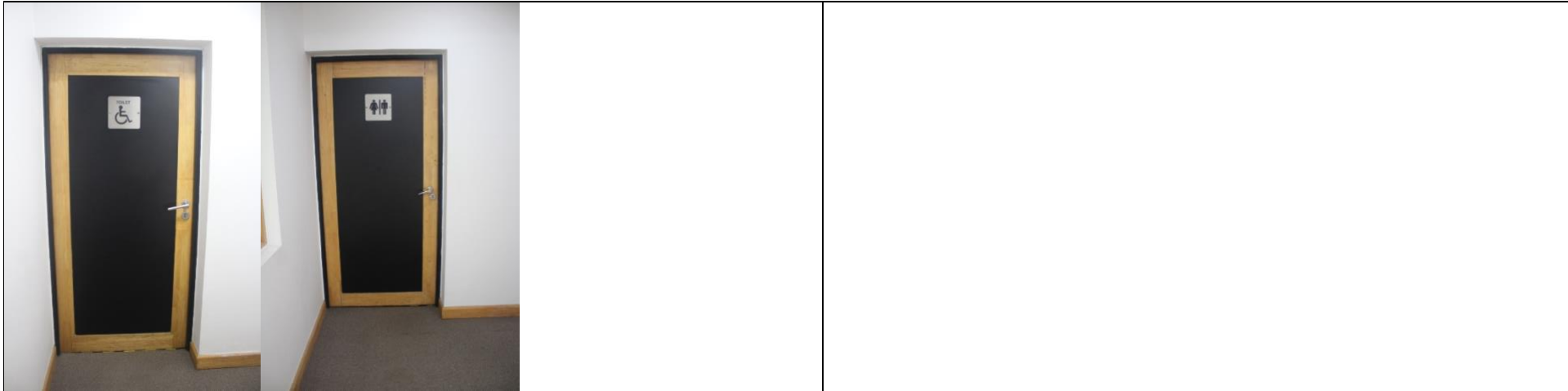

Result: Signage is Non-Compliant and Inaccessible

SECTION B – WORK ACCESS

PERSONAL CABINS (HALF & FULL)

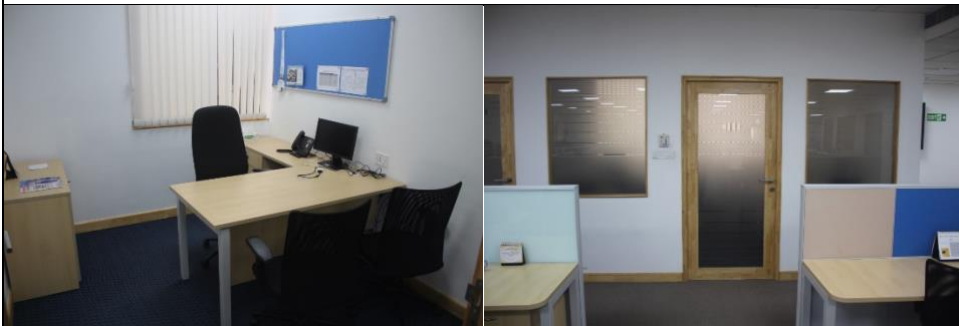

- All the full cabin entry doors have handles placed at non-compliant heights making these entries non-compliant
- Some of the full cabin entry doors have high door tension, some have non-compliant door widths and some have signage placed at non-compliant to inaccessible heights with no provisions for braille and tactile whereas the rest of the full cabins do not have an accessible signage at all making all the full cabin entries non-compliant and largely inaccessible for PwDs
- The ground floor VP cabin and one of the second floor corner full cabin don't have push side door clearances making these entries inaccessible for certain PwDs



- One of the half cabins on second floor as marked in the floor plan has non-compliant entry width
- Most of the personal cabins have non-compliant and/or inaccessible chair clearances as marked in the floor plans (except for the rooms that were locked and not reviewed) and few of them have non-compliant and/or inaccessible entry widths towards the users' side of the table making these cabins non-compliant and hard for PwDs to use
- Few of the personal cabins have marker holders placed along the movement route in which case they may act as projections and can be unsafe for certain PwDs
- All the whiteboards placed in the personal cabins are at heights which reduces the optimal usage area for certain PwDs
- Cable cubbies for two of the personal cabins on ground, first and second floor each are placed at non-compliant depths or inaccessible points
- All the cabins have light switches placed at non-compliant heights with no colour contrast against the background wall making them non-compliant

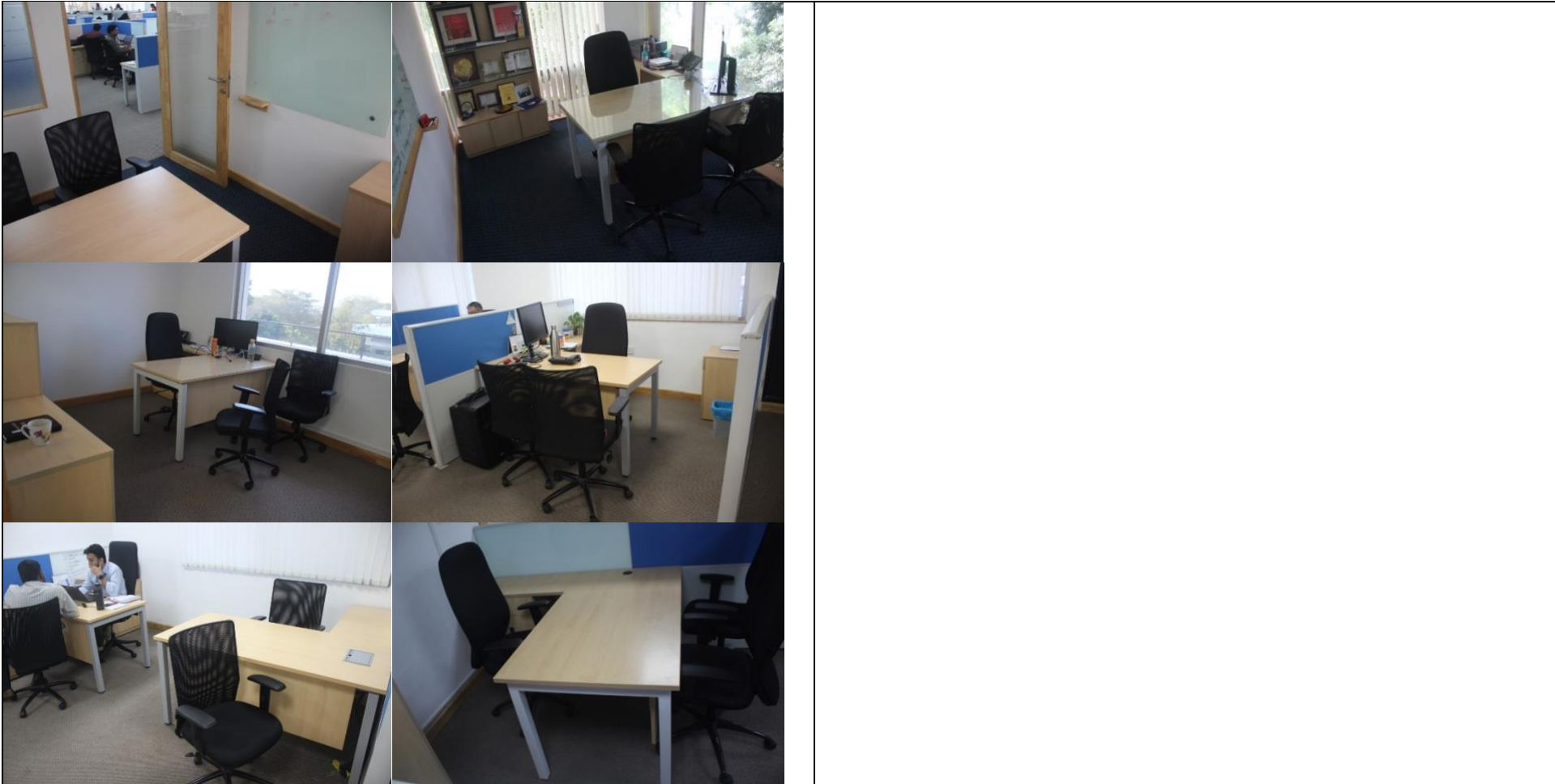

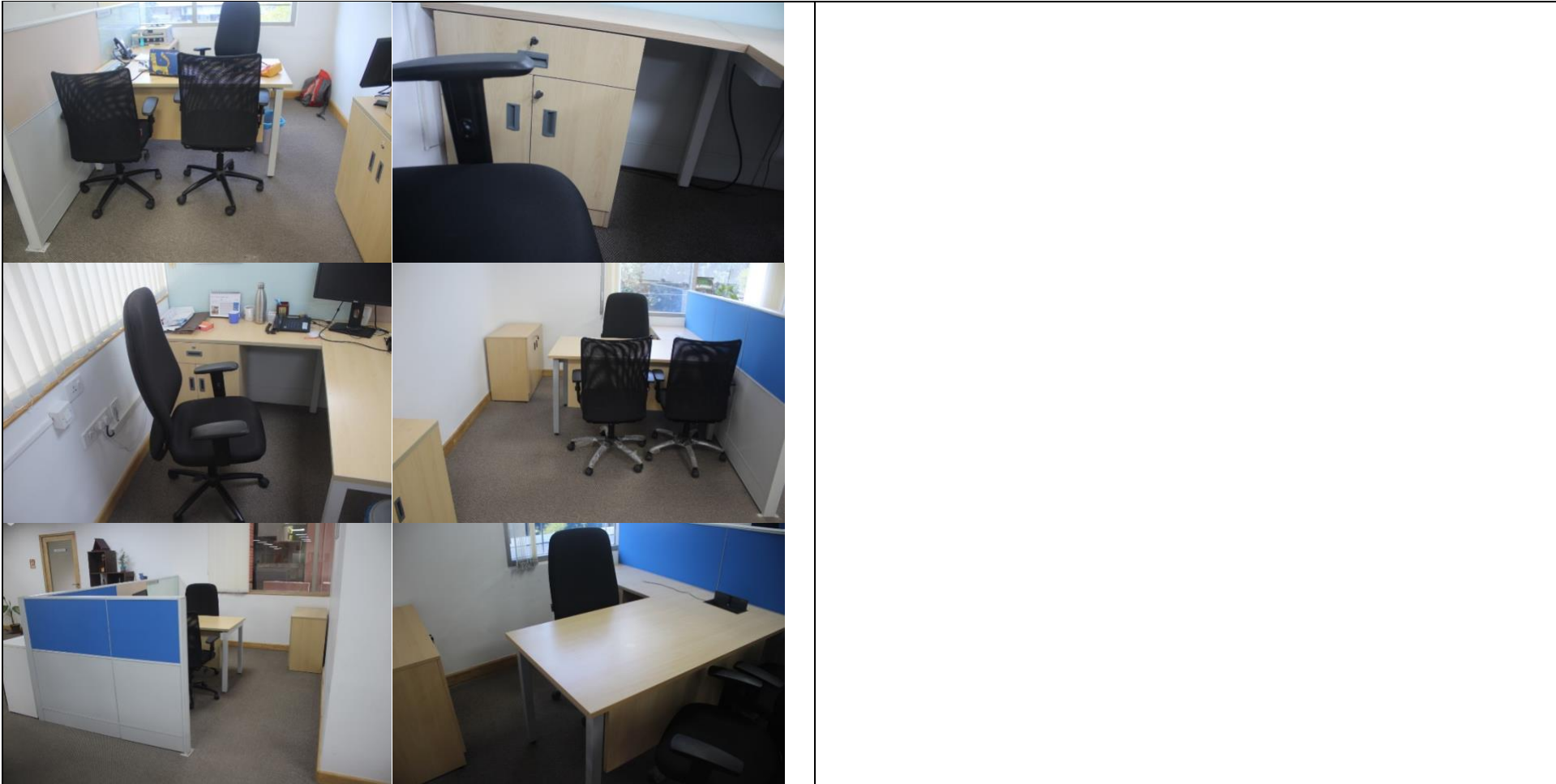

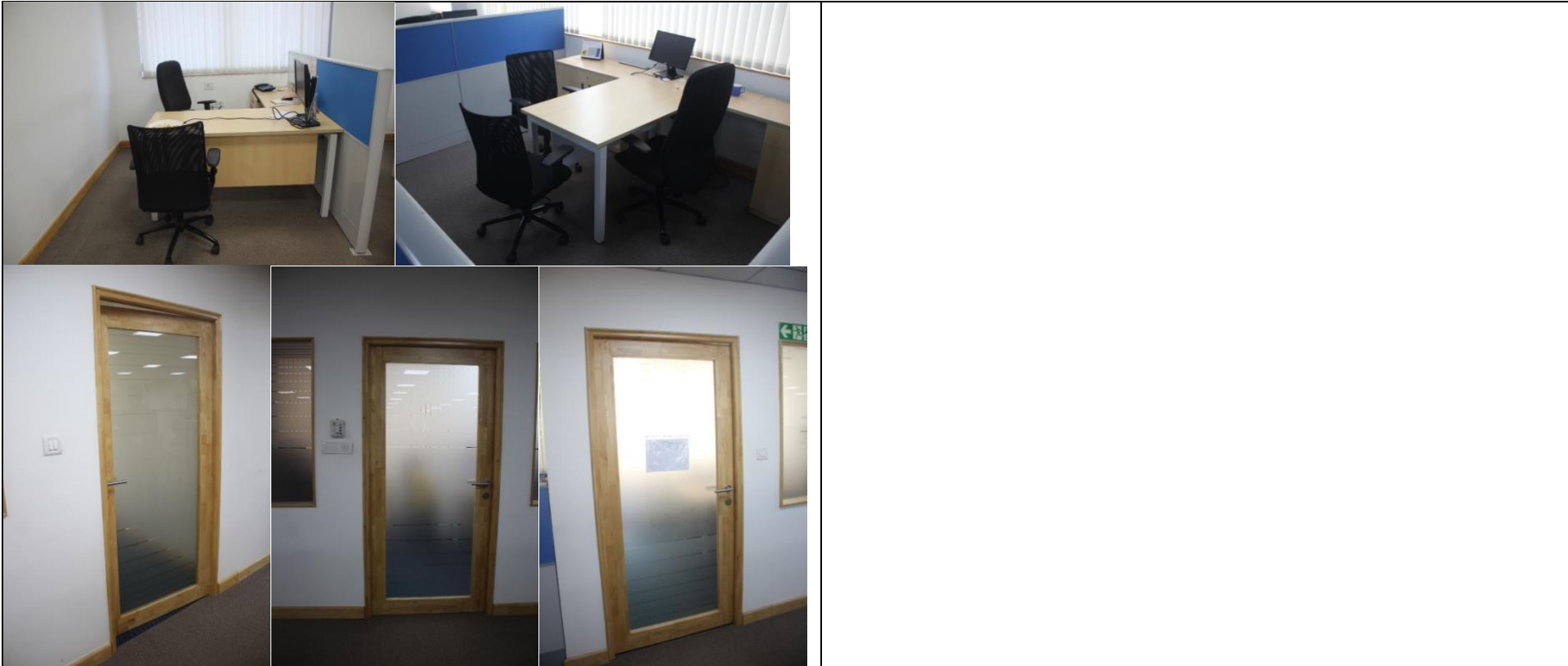

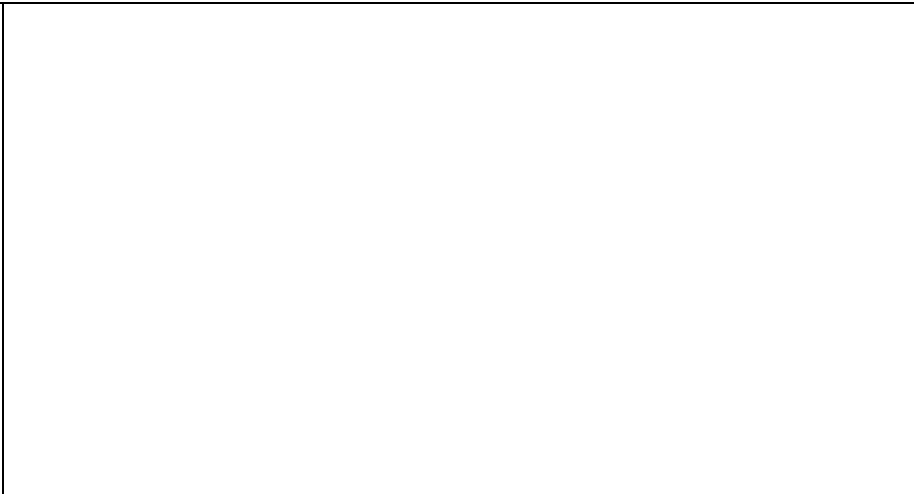

Result: Personal Cabins are Non-Complaint and Partially Inaccessible

WORK AREA CIRCULATION

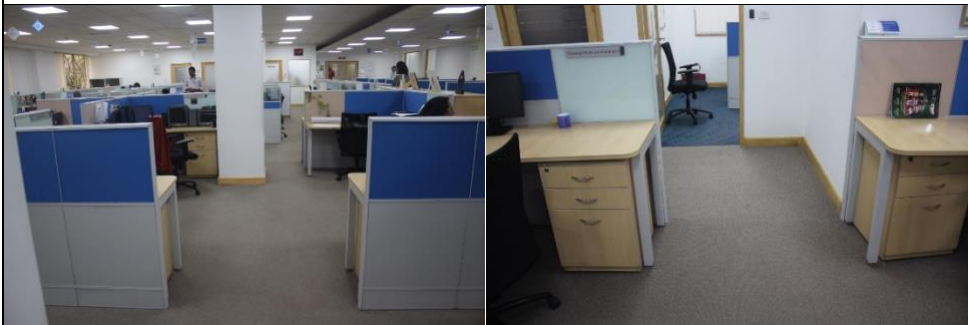

➤ A lot of points in the circulation paths and cubicle entries across the work floors have inaccessible widths as marked in the floor plans which will make the areas beyond these points completely inaccessible for PwDs

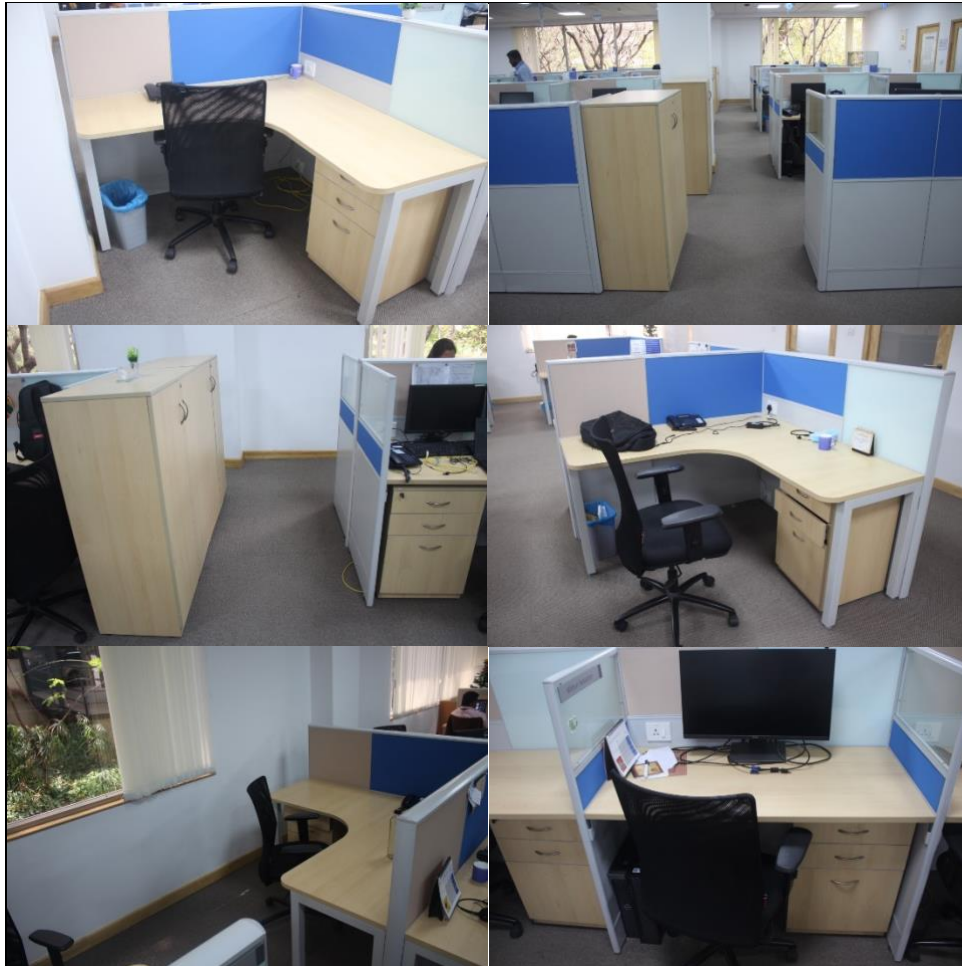

- A lot of points in the circulation paths and cubicle entries across the work floors have non-compliant widths and some of the pathways around the work seating in the circulation paths have practically hard to navigate widths as marked in the floor plans and will act as roadblocks for PwDs making these areas practically difficult for PwDs to navigate around
- Most of these inaccessible, hard to navigate and non-compliant circulation path widths and points have been created because of the placement design of the work stations not accommodating movement space required to move in a particular area
- There are multiple seats across the work floors that have inaccessible and/or non-compliant chair clearances as marked in the floor plans and will be inaccessible for certain PwDs
- The ratio of inaccessible and non-compliant points together is high throughout the work floors and while they may not be used directly by certain PwDs, it will still be hard for these PwDs to coordinate with team members seated here creating challenges in coordination
- Most of the work floors have a high ratio of inaccessible and non-compliant points and passage ways except for the linear style seating layouts which will be manageable making the rest of the floor hard for certain PwDs to work or access team members here
- Some of the work area passages have storage units and/or printers placed that compromise the passage width there as well as compromising access space required for the storage units and the printers
- The linear style workstations have keyboards that compromise knee clearances for wheelchair users making these workstations inaccessible to use
- The workstation storage pedestals as well as storage cabinets are inaccessible for people with certain types of hand impairment because of the locking mechanism and handle type

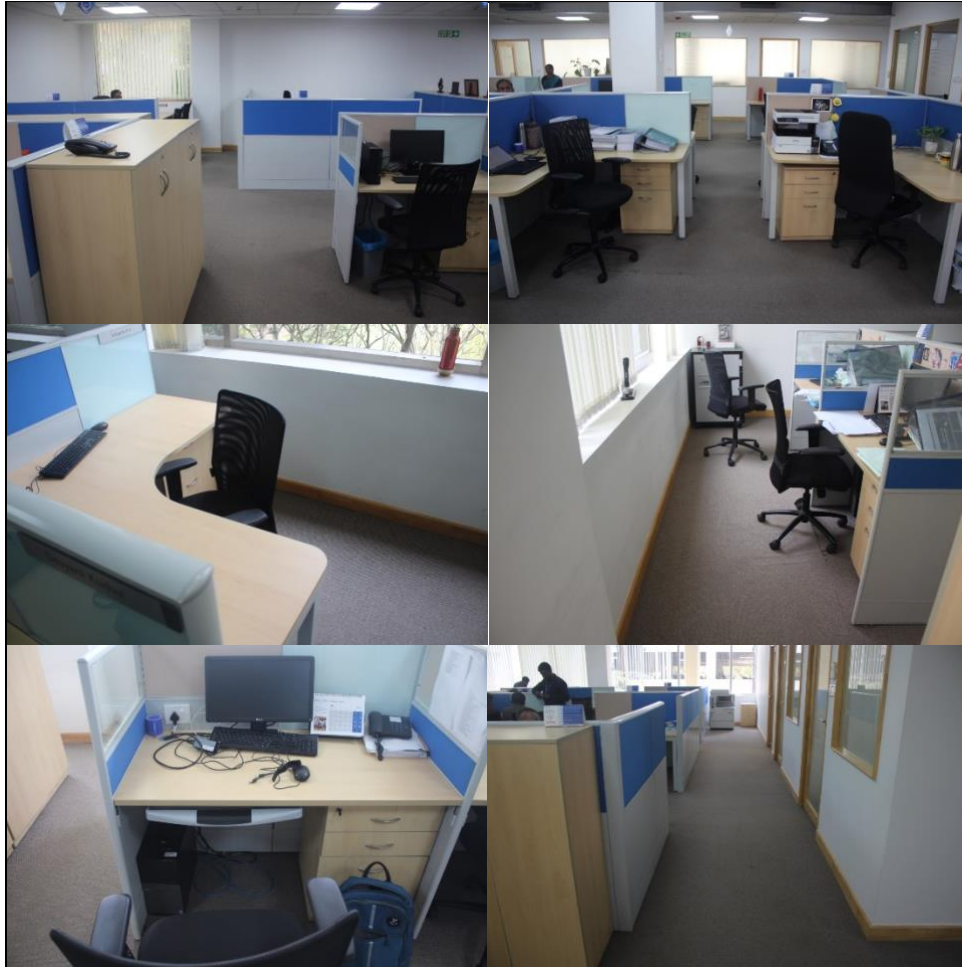

- The workstation storage pedestals as well as storage cabinets need braille labels as when people with visual impairment are hired in those areas

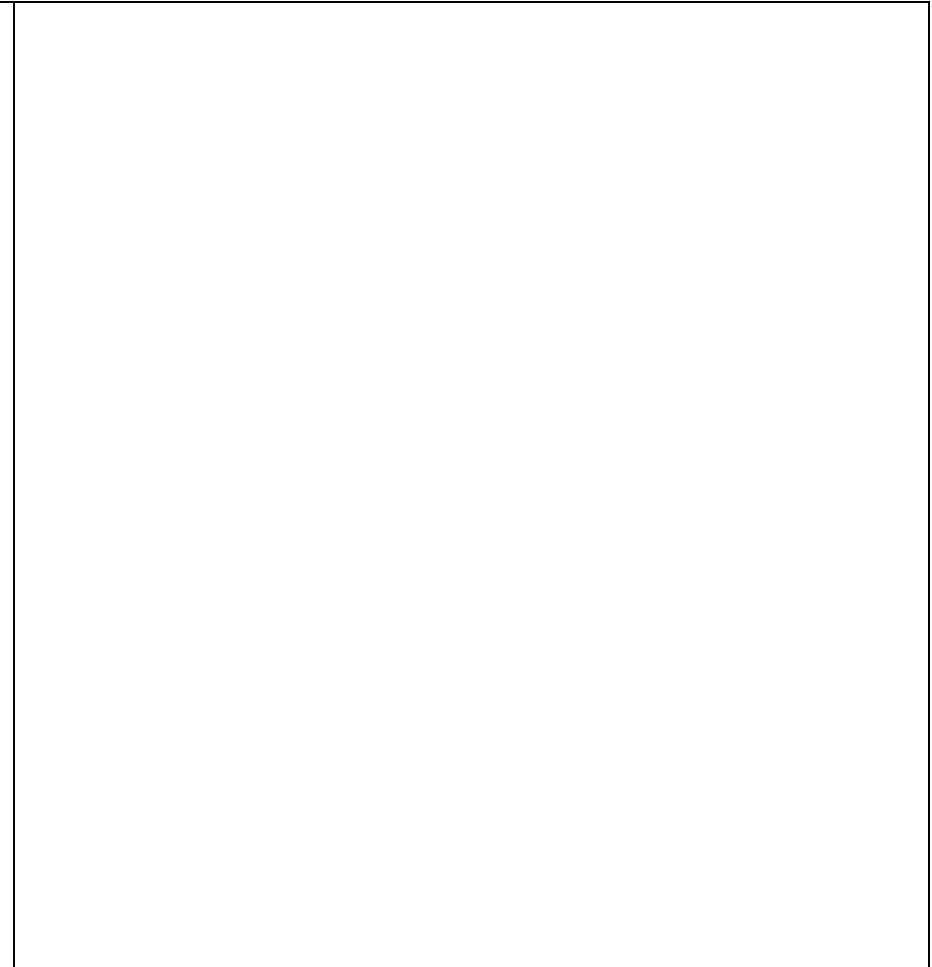

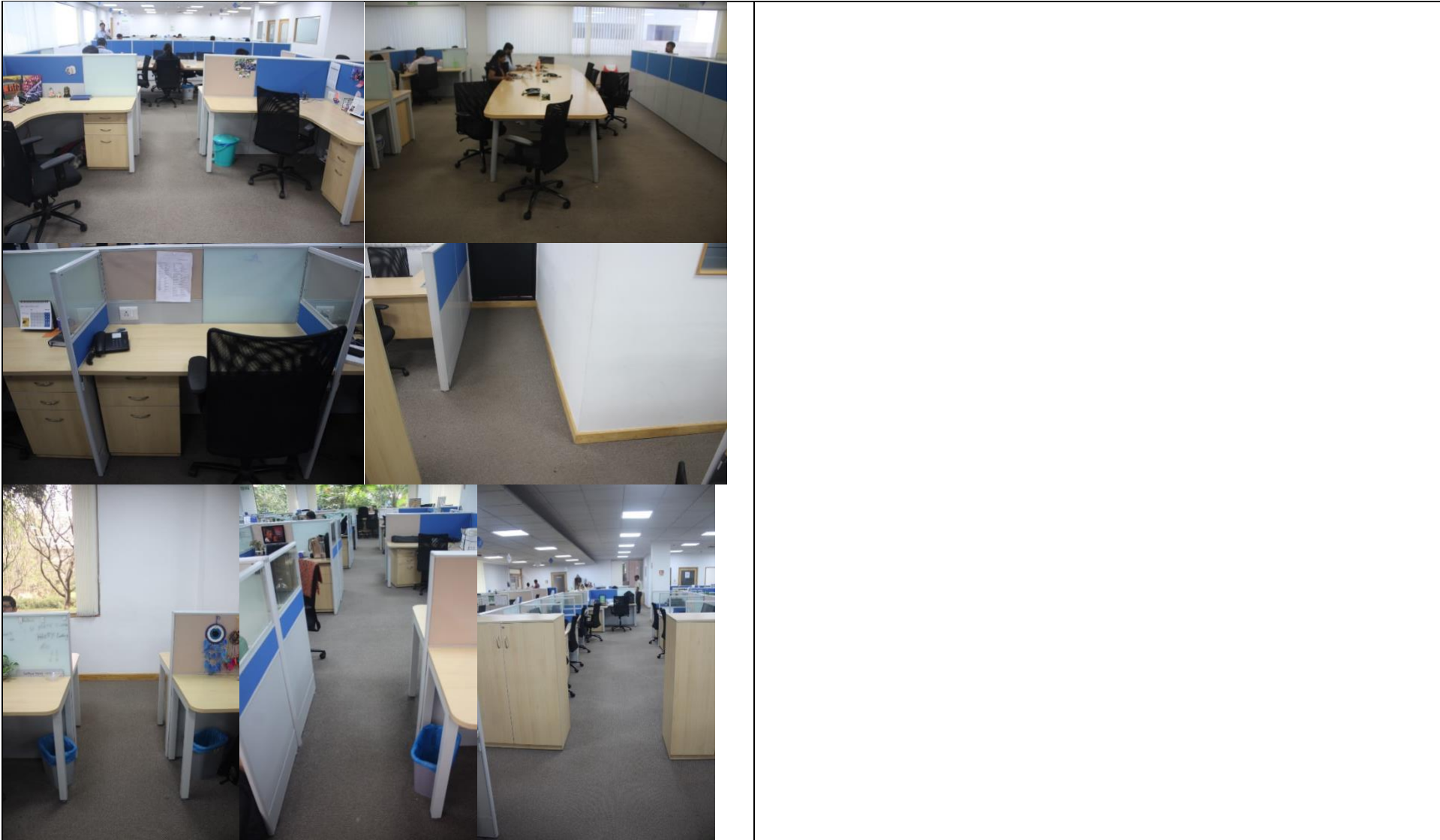

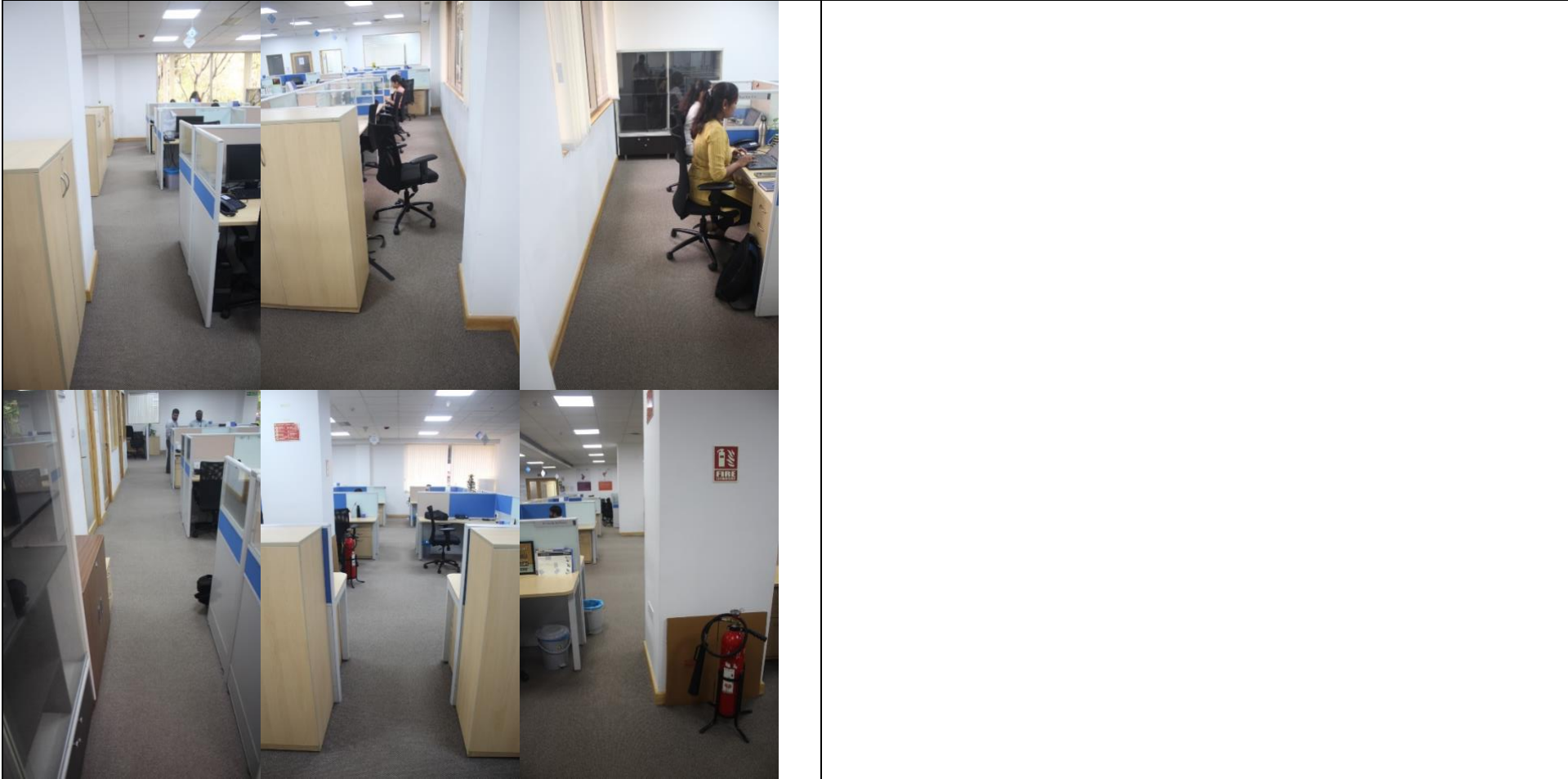

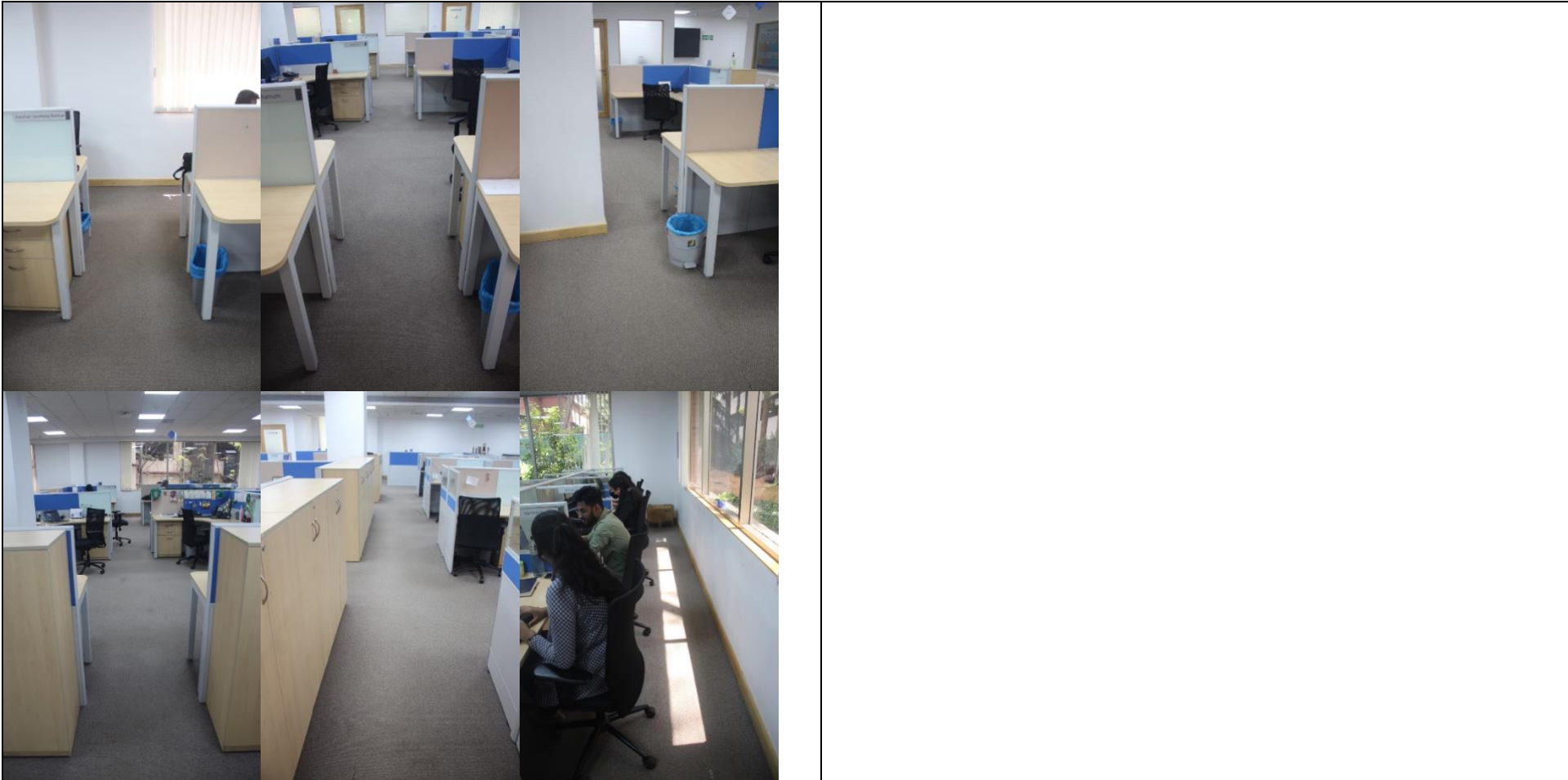

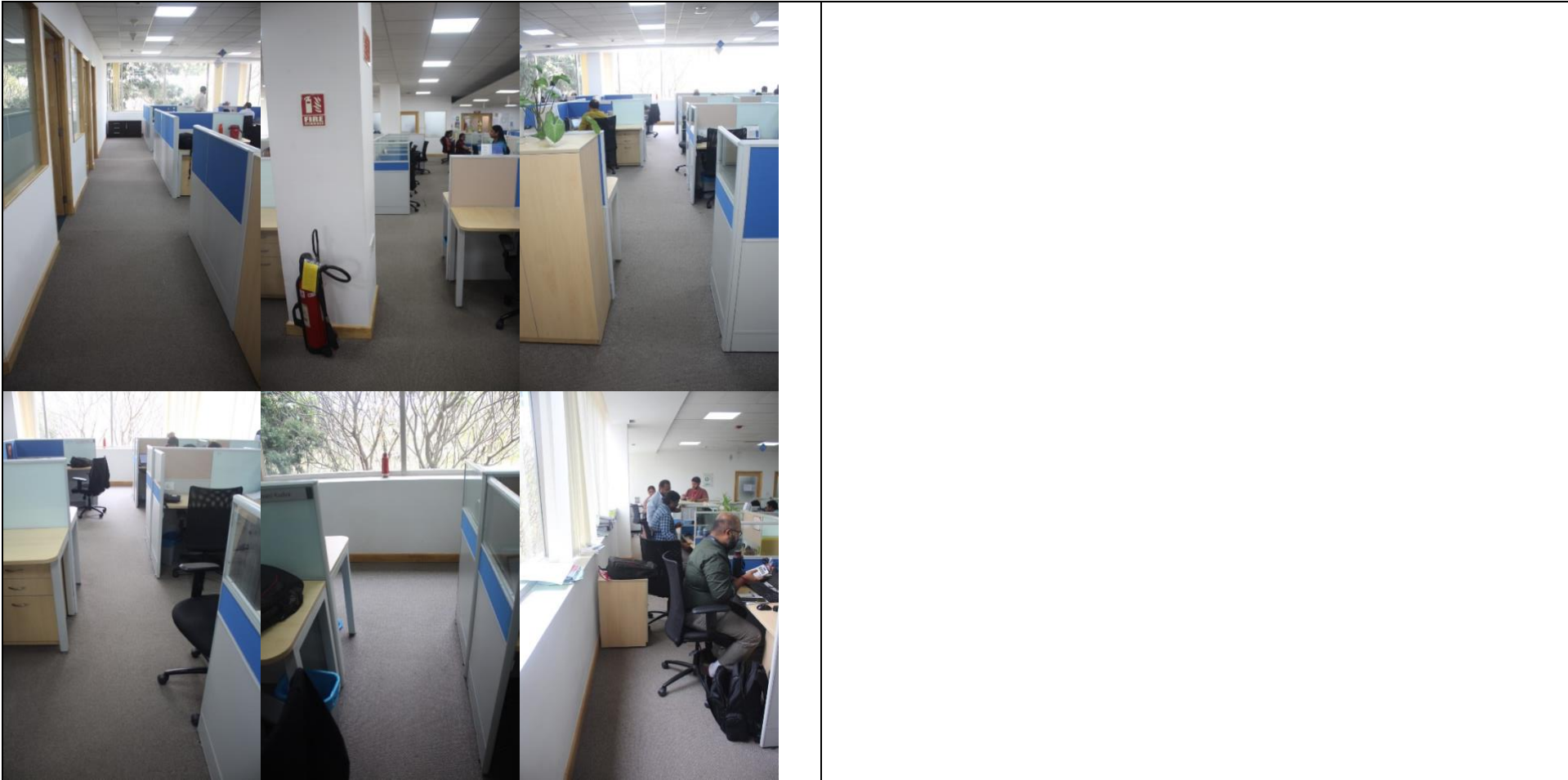

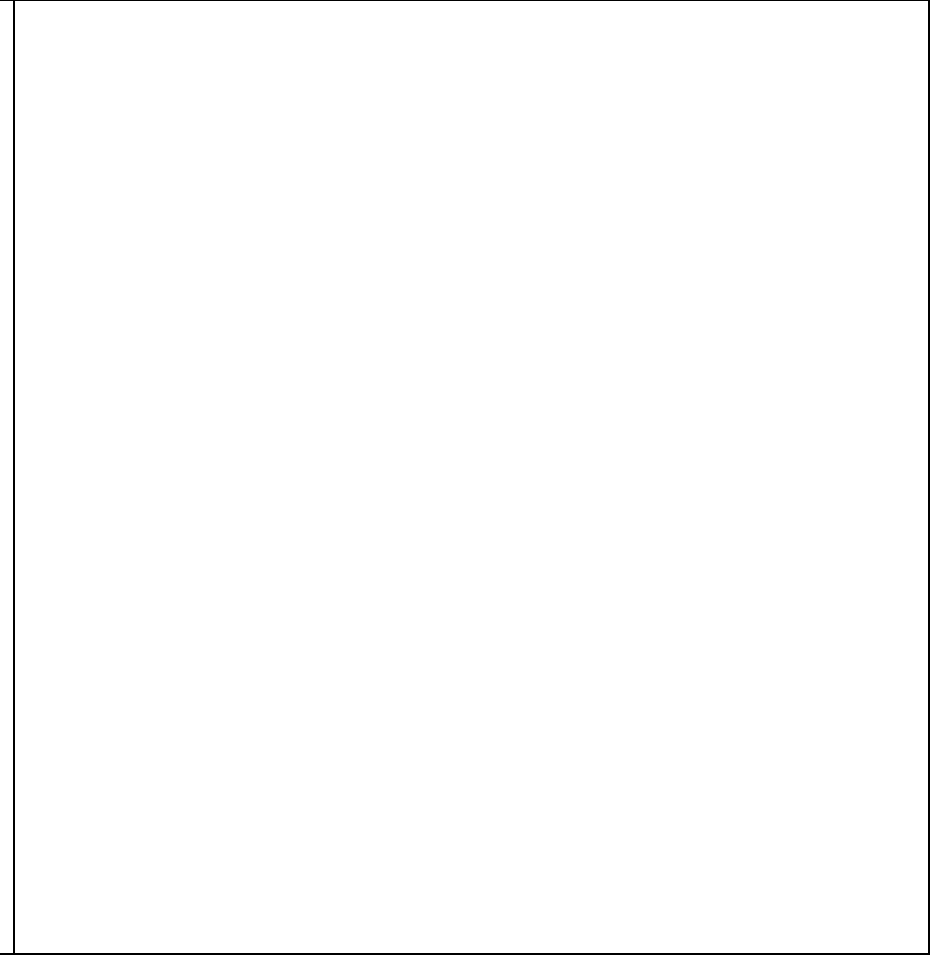
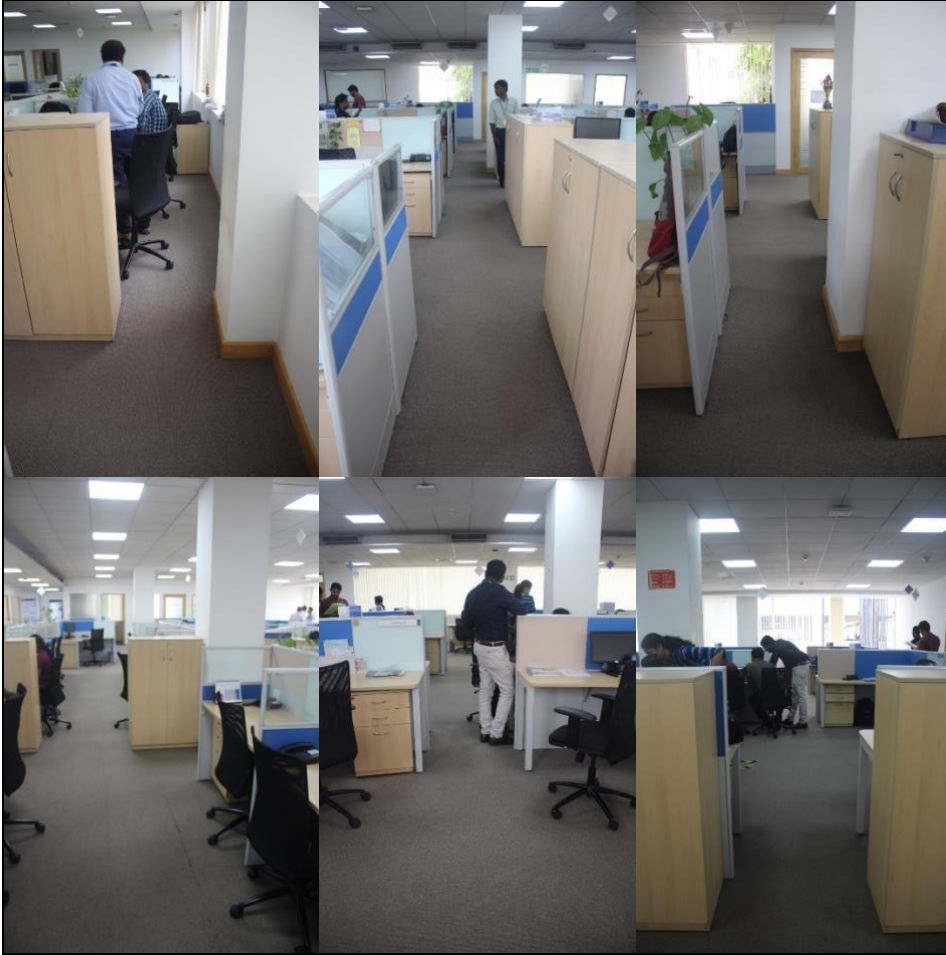

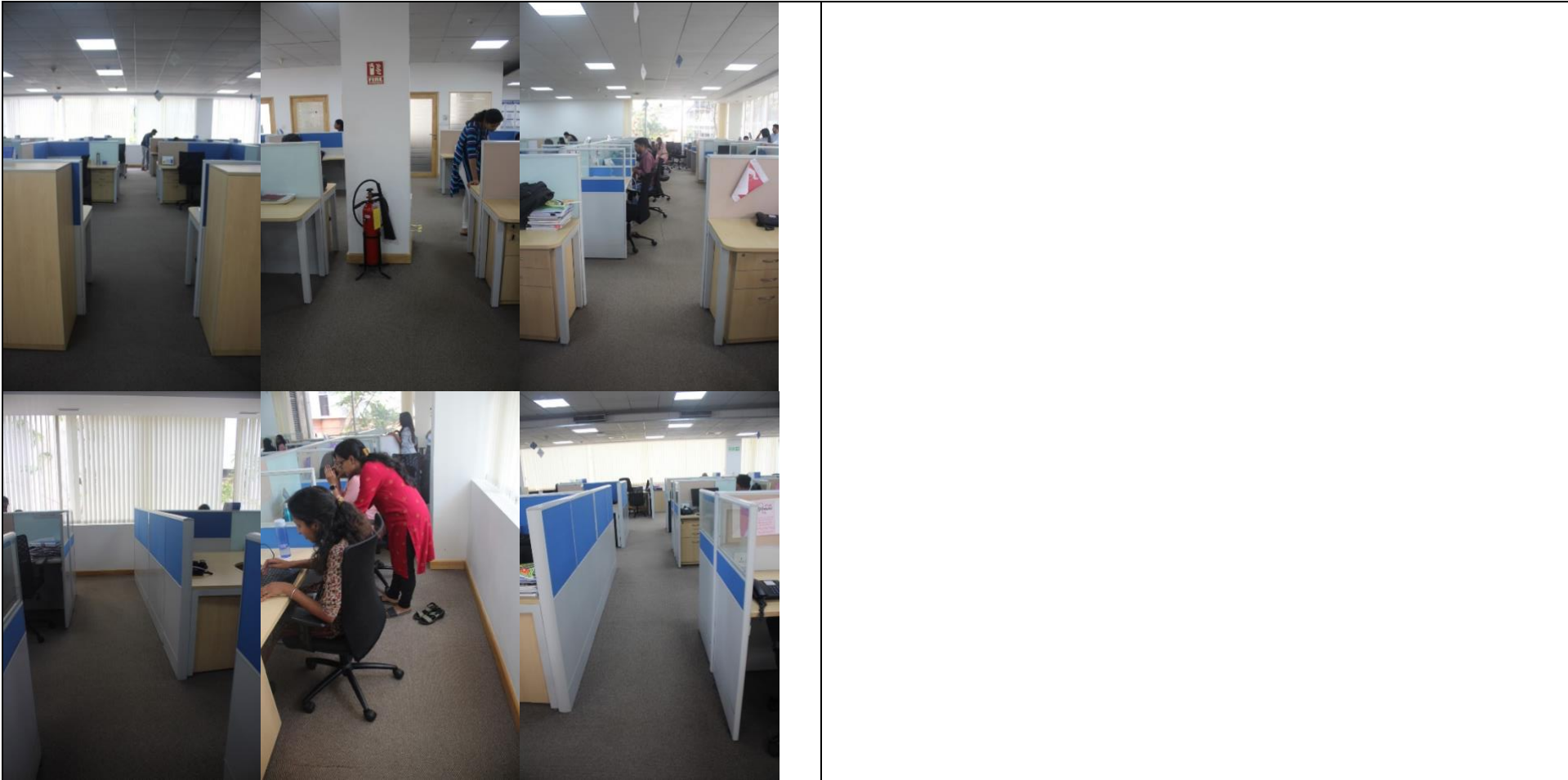

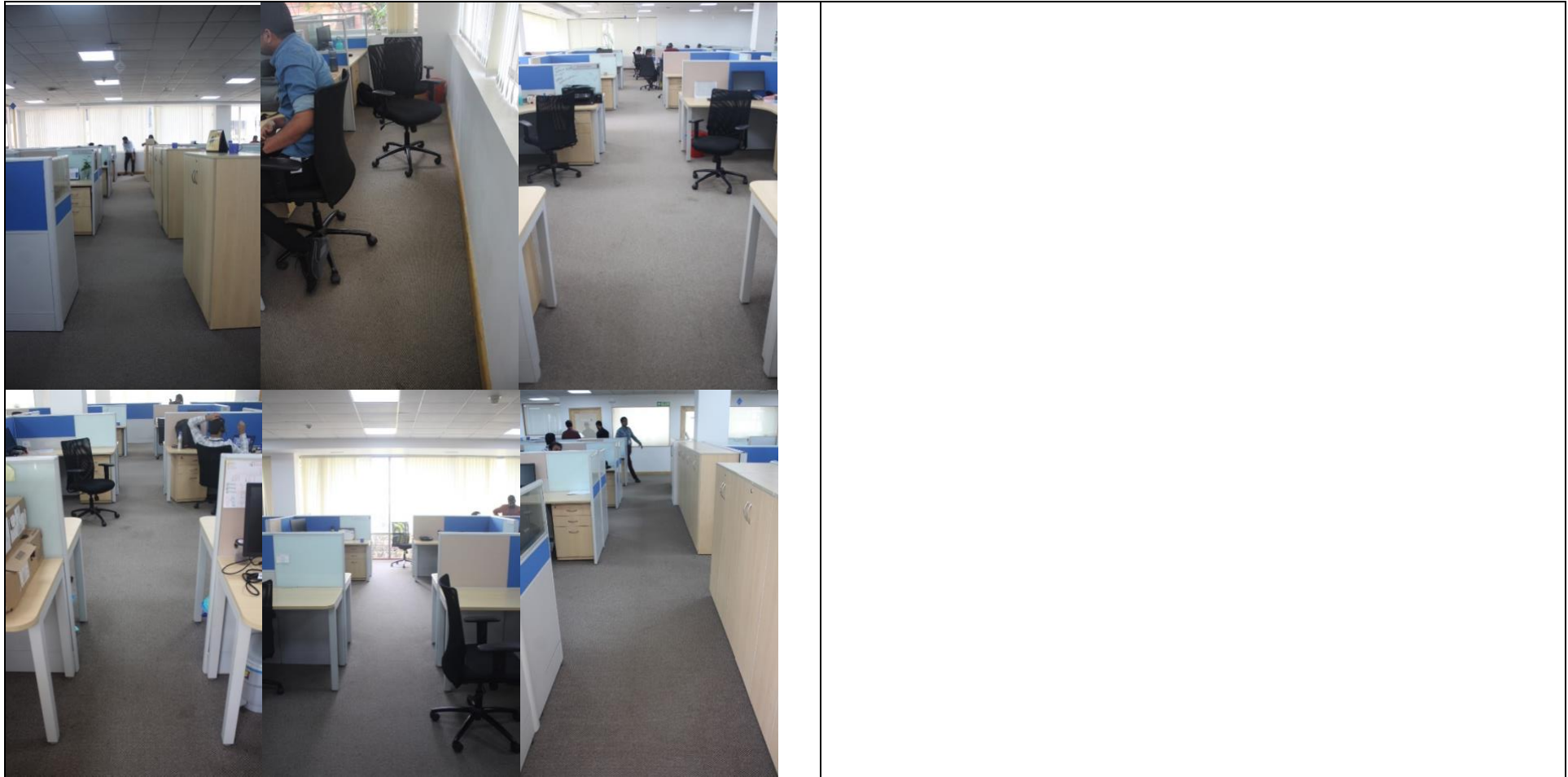

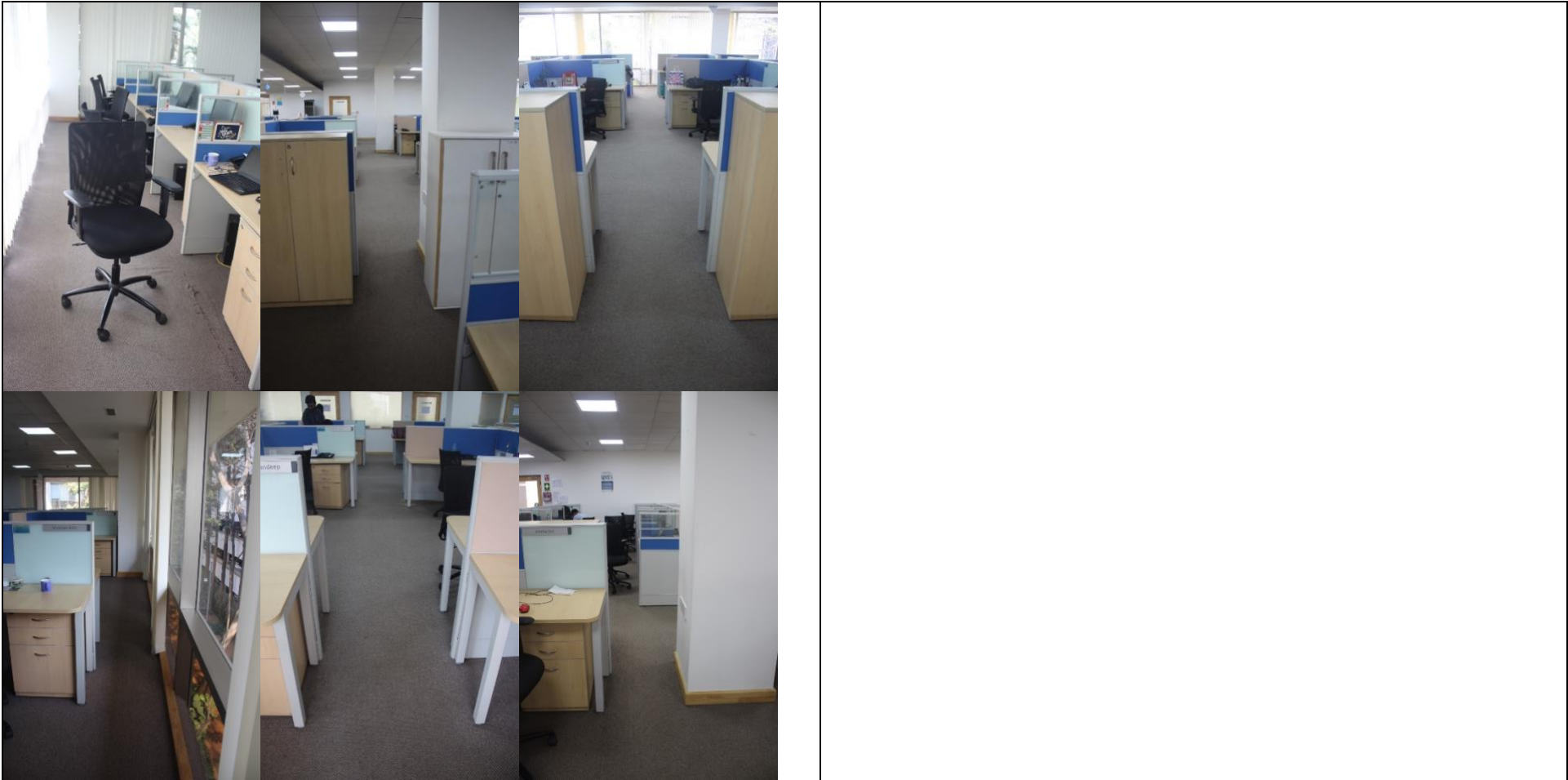

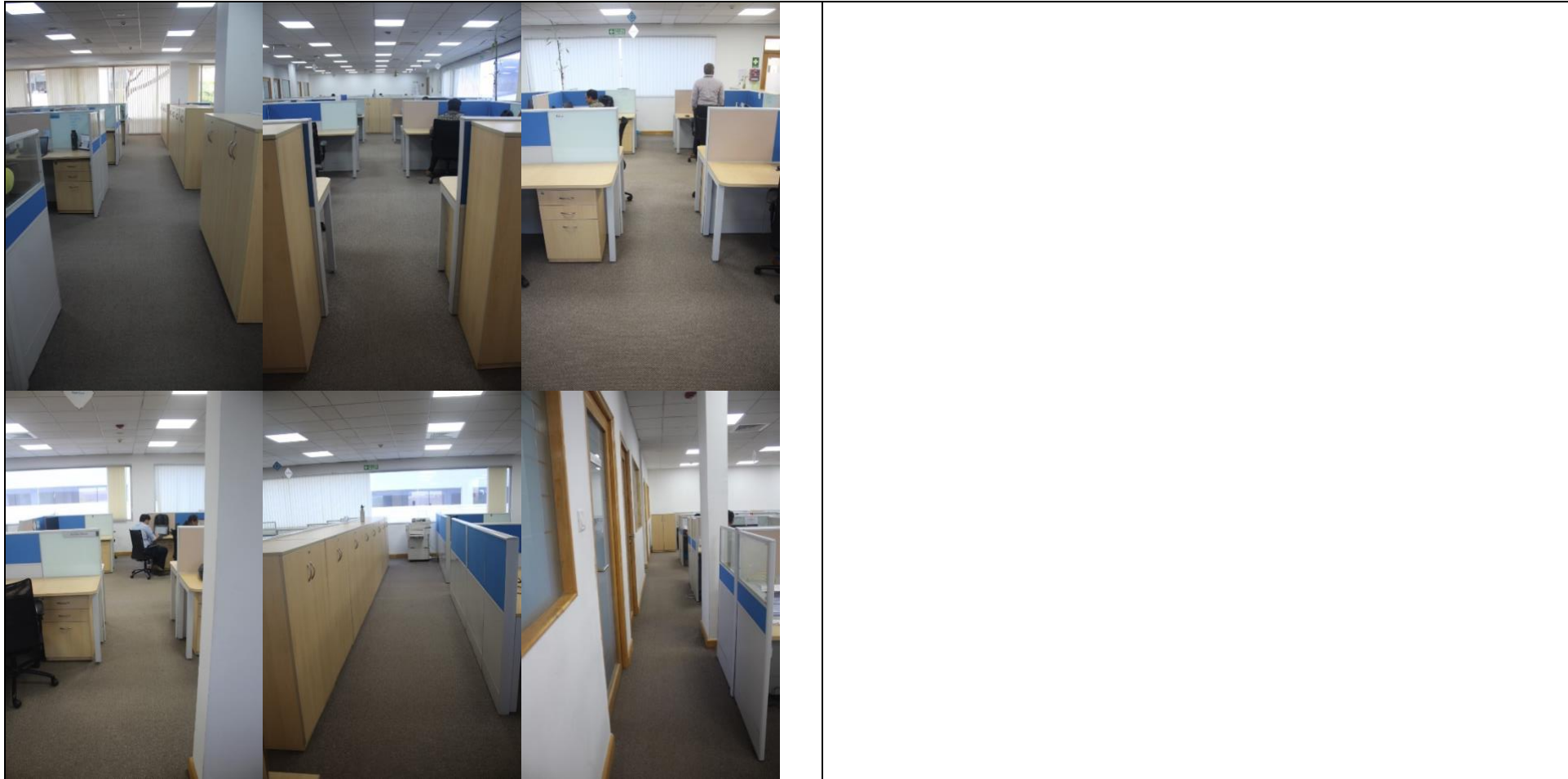



Result: Work Area Circulation is Non-Compliant and Partially Inaccessible

PRINTERS



- A lot of the printers across the work floors do not have clear access space in front of them for wheelchair users to be able to access and use them
- The table top printers are placed at inaccessible heights for certain PwDs to be able to use it
- There is no identification or directional signage marking the placement of printer in the floor with provisions for braille and tactile making it non-compliant
- None of the printers have audio out provision making them inaccessible for people with visual impairment



Result: Printers are Non-Complaint and Partially Inaccessible

SECTION C – FACILITIES

PWD RESTROOMS	
	➤ There is no PwD restroom in the third floor at all making this floor non-compliant and completely inaccessible for certain PwDs

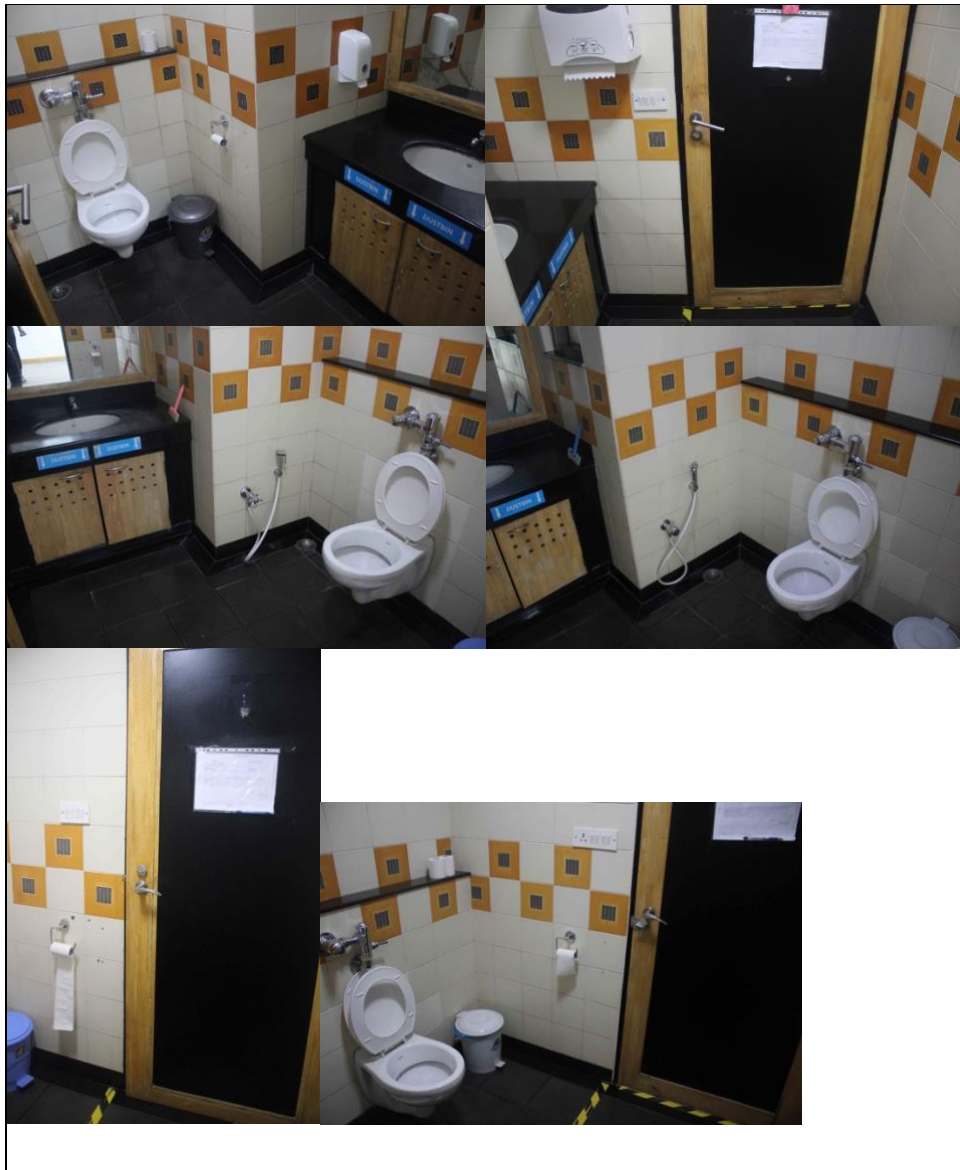

- The ground floor PwD restroom access is via a corridor that has non-compliant path width
- All three PwD restrooms have signage placed at non-compliant heights with no provisions for braille and tactile and inappropriate text and symbols making these signage and the identification process non-compliant and inaccessible
- All three PwD restrooms have high door tension making them inaccessible for PwDs
- All three PwD restrooms have non-compliant dimensions and fixtures placed in a layout that compromises circulation inside the room as well as the transfer space for wheelchair users making all three restrooms completely inaccessible for PwDs
- All three PwD restrooms have inward opening doors with no push bars and kick plates and inaccessible type of hand sink taps making them non-compliant and inaccessible for PwDs
- All three PwD restrooms don't have the required supportive aids for WC and hand sinks with 38-45 mm diameter as required by compliance, accessible hand sinks, emergency alarms and accessible 30 degree tilt mirrors as per compliance making them inaccessible for PwDs
- The first and second floor PwD restrooms have non-compliant door widths, ground and first floor PwD restrooms have non-compliant handle heights and the ground floor PwD restroom has inaccessible pull side door clearance making these entries non-compliant and inaccessible for PwDs
- Both the soap dispensers and the tissue paper dispensers are placed at non-compliant to inaccessible heights in all the three restrooms making them inaccessible for PwDs
- All the three PwD restrooms have back flush setup placed on the wall behind the WCs which are non-compliant and inaccessible for PwDs
- All the three PwD restrooms have light switches placed at non-compliant and inaccessible heights with no colour contrast against the

	<p>background wall making them non-compliant and inaccessible for PwDs</p> <ul style="list-style-type: none"> ➤ All the three PwD restrooms do not have braille and tactile toilet layouts to support PwDs as required by compliance ➤ All the three PwD restrooms have slippery floors that can be unsafe for PwDs and are non-compliant ➤ None of the PwD restrooms have a blinker connected to the emergency system in case of an emergency as required by compliance to support people with hearing impairment
--	---

Result: PwD Restrooms are Non-Compliant and Partially Inaccessible

MEN'S & WOMEN'S RESTROOMS

	<ul style="list-style-type: none"> ➤ All the men's and women's restrooms' in the office building have entry doors with high door tension, non-compliant and/or inaccessible door widths, handles placed at non-compliant heights, and signage placed at non-compliant to inaccessible heights with no provisions for braille and tactile making these entries non-compliant and inaccessible for PwDs ➤ All the women's restrooms' in the office building have inaccessible pull side door clearances making them inaccessible for people with ambulatory disabilities ➤ All the men's and women's restroom entry doors in the office building have minor ledges at entry doors that can be unsafe for people using mobility aids ➤ Both the first and second floor conference room toilets have high door tension, inaccessible door widths, non-compliant handle heights, and
--	---



	<p>signage with no provisions for braille and tactile making entry to these toilets non-compliant and inaccessible for certain PwDs</p>
<p>➤</p>	<p>The first floor conference room toilet does not have pull side door clearance and the tissue paper holder placed in the niche acts as a projection making it unsafe and the entry inaccessible for certain PwDs</p>
<p>➤</p>	<p>Both the first and second floor conference room toilets are congested and will be hard for certain PwDs to use these restrooms</p>
<p>➤</p>	<p>Both the canteen men's and women's restrooms have signage placed at inaccessible and non-compliant heights with no provisions for braille and tactile making these entries non-compliant</p>
<p>➤</p>	<p>All the men's restrooms have urinals at step levels that makes them harder to access and use for people with ambulatory disabilities and additionally reduces the clear space in front of the urinals for access making them non-compliant and inaccessible</p>
<p>➤</p>	<p>None of the men's restrooms have an accessible urinal at an appropriate height with supportive aids as required by compliance making it hard for people with ambulatory disability to use restroom facilities</p>
<p>➤</p>	<p>Neither of the men's or women's restrooms have a provision for one ambulatory disabled-friendly cubicle per restroom and are inaccessible additionally because of the inward opening doors, inaccessible entry door widths, non-compliant handle types or heights and lack of supportive aids for the ambulatory disabled making them non-compliant and inaccessible for the ambulatory disabled</p>
<p>➤</p>	<p>All the restrooms have slippery floors that can be unsafe and are non-compliant</p>
<p>➤</p>	<p>Some of the restrooms have hand dryers and/or tissue paper holders placed at points where they act as projections and can be unsafe for PwDs and are non-compliant</p>
<p>➤</p>	<p>Some of the restrooms have loose mats near the entry doors or hand sinks which can be unsafe for certain PwDs and are non-compliant</p>

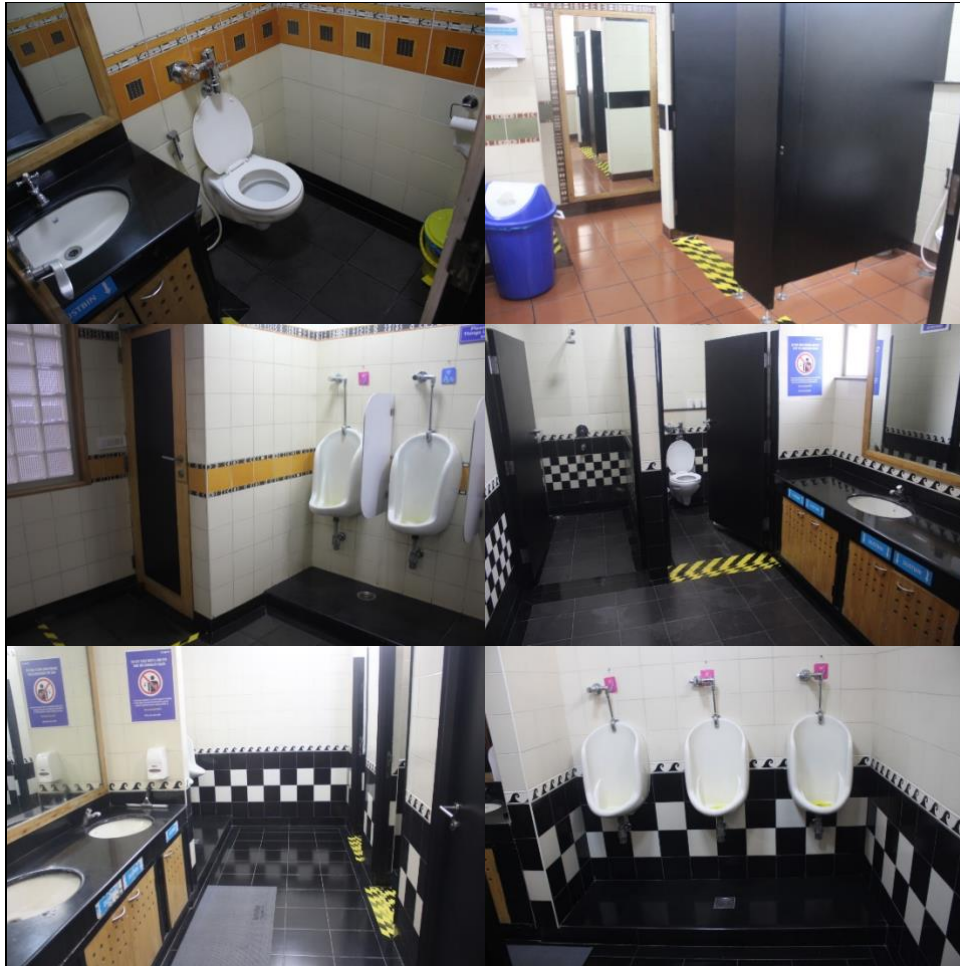

- None of the restrooms have blinkers connected to the emergency system in case of an emergency as required by compliance

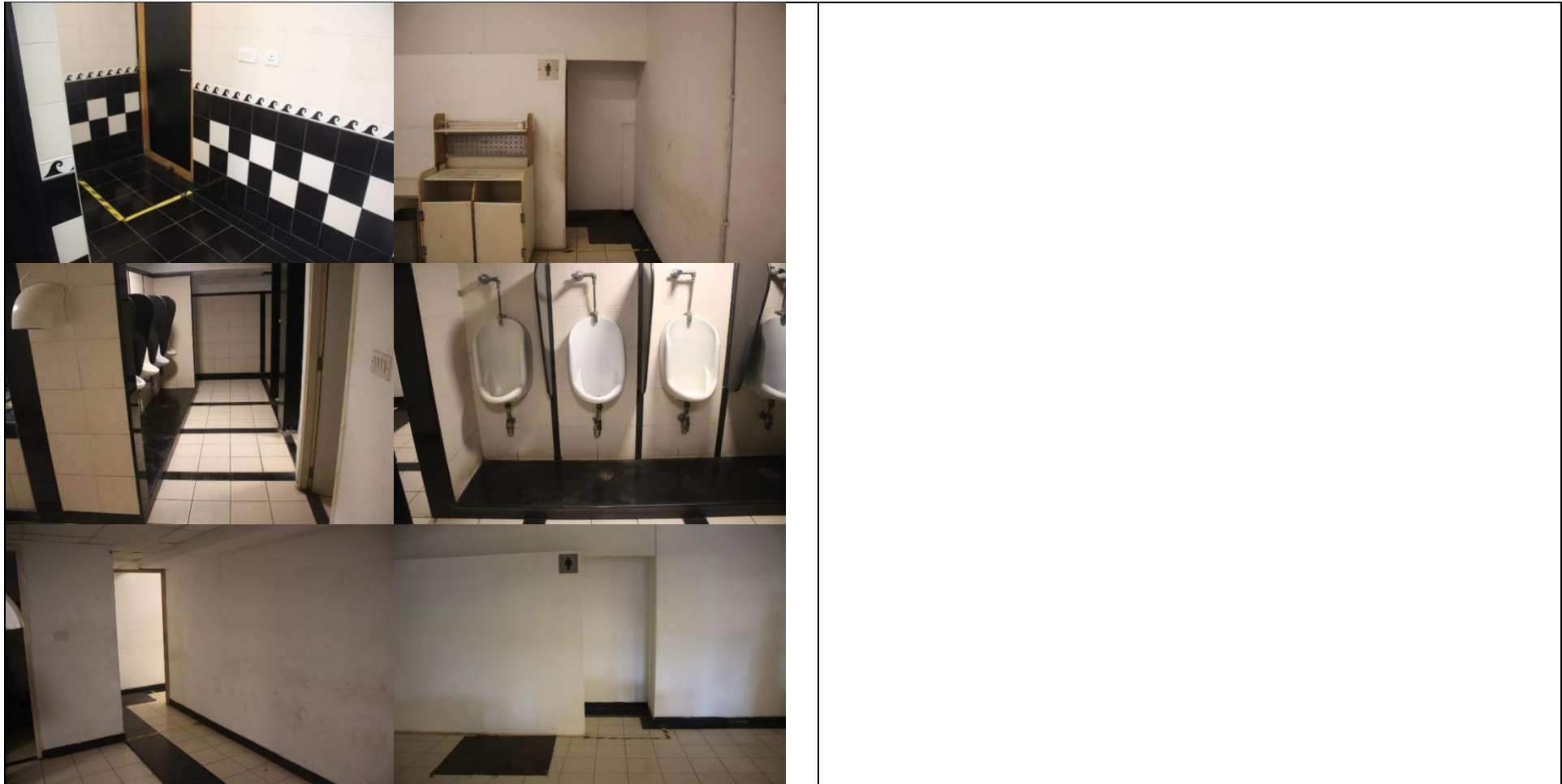

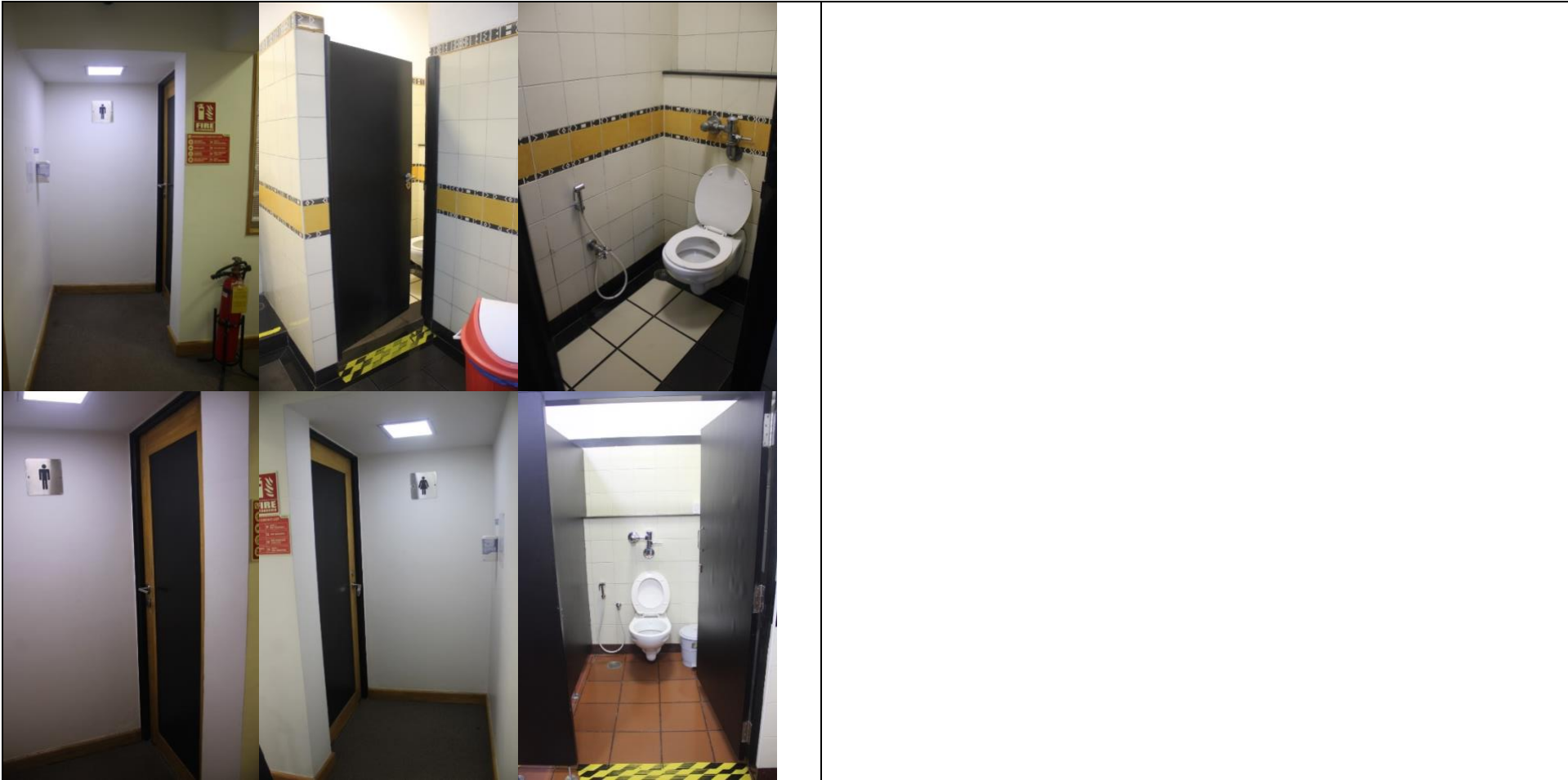



Result: Men's & Women's Restrooms are Non-Compliant and Inaccessible

CONFERENCE ROOMS

- All the conference rooms' entry doors have high door tension, non-compliant door widths (except for one conference room in second



	<p>floor), and handles placed at non-compliant heights except for the conference rooms with long vertical handles that are placed at inaccessible heights making these entries non-compliant and inaccessible for PwDs</p>
➤	<p>All the conference rooms with signage have them placed at non-compliant heights with no provisions for braille and tactile and the rest don't have signage at all making these entries non-compliant and inaccessible</p>
➤	<p>The conference room on first floor with toilet has non-compliant and inaccessible pull side door clearance making this entry non-compliant and inaccessible to access for certain PwDs</p>
➤	<p>Most of the conference rooms have non-compliant and/or inaccessible chair clearances as marked in the floor plans making these rooms either completely and/or that part of the conference room inaccessible and non-compliant for PwDs</p>
➤	<p>None of the conference rooms have loop induction units as per compliance to support people with hearing impairment</p>
➤	<p>All the conference rooms have whiteboards placed at heights that reduces the optimal usage area for certain PwDs</p>
➤	<p>Some of the conference rooms have marker holders that may act as projection and be unsafe for PwDs</p>
➤	<p>The conference room in the second floor with the toilet inside has cable cubbies placed at inaccessible depths making them inaccessible for certain PwDs to access and use</p>
➤	<p>The light switches in all conference rooms are placed at non-compliant heights with no colour contrast against the background walls making them non-compliant</p>

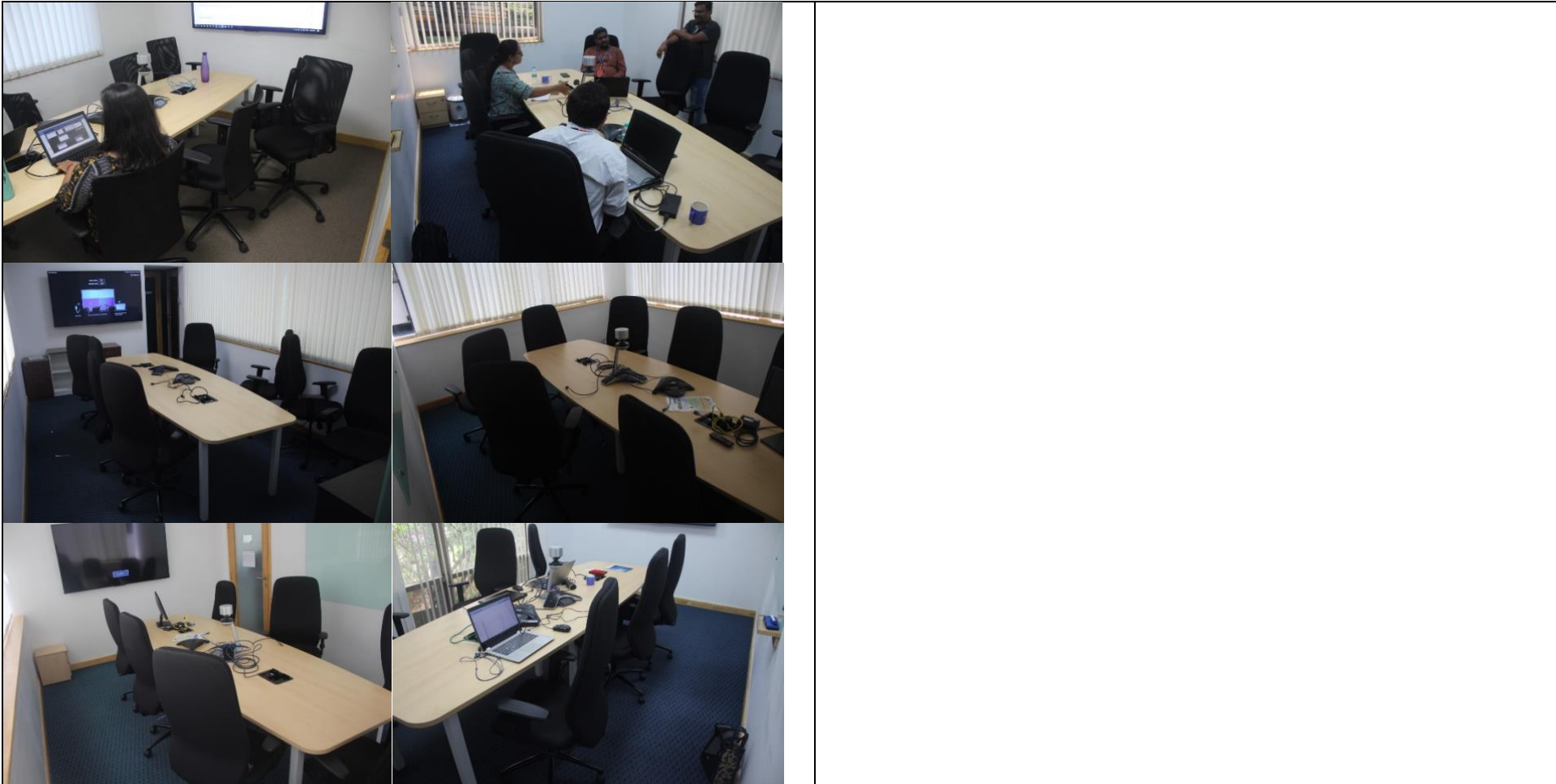



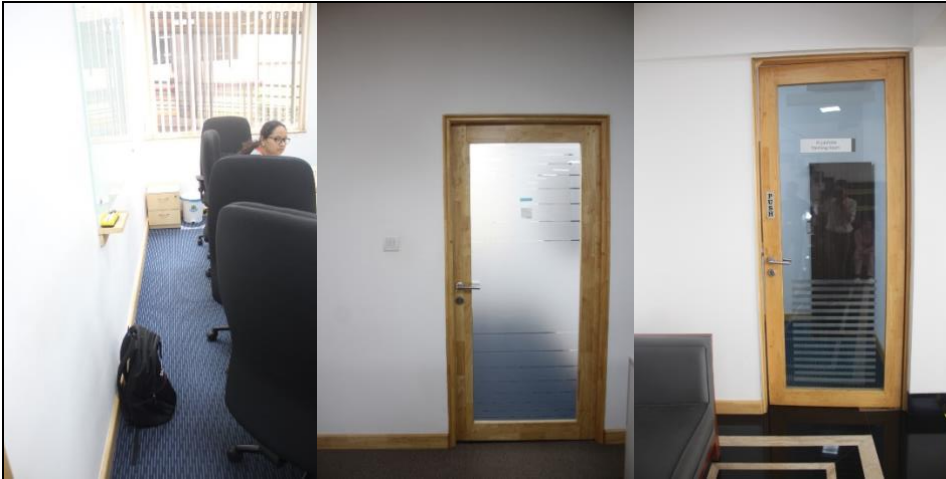

Result: Conference Rooms are Non-Complaint and Partially Inaccessible

MEETING ROOMS



- All the meeting room entry doors have high door tension (except for three meeting rooms in the second floor), non-compliant door widths (except for one of the meeting rooms on first floor and three of the meeting rooms on second floor) and handles placed at non-compliant heights except for one of the meeting rooms with vertical long handles which is placed at inaccessible height making these entries non-compliant and inaccessible for PwDs
- All the meeting room entry doors have signage placed at non-compliant to inaccessible heights except for two that are at accessible heights and two that have no signage in place at all and none of the signage in place has provisions for braille and tactile making these entries non-compliant and inaccessible for certain PwDs
- Few of the meeting rooms have inaccessible pull and push side door clearances making these entries inaccessible for PwDs

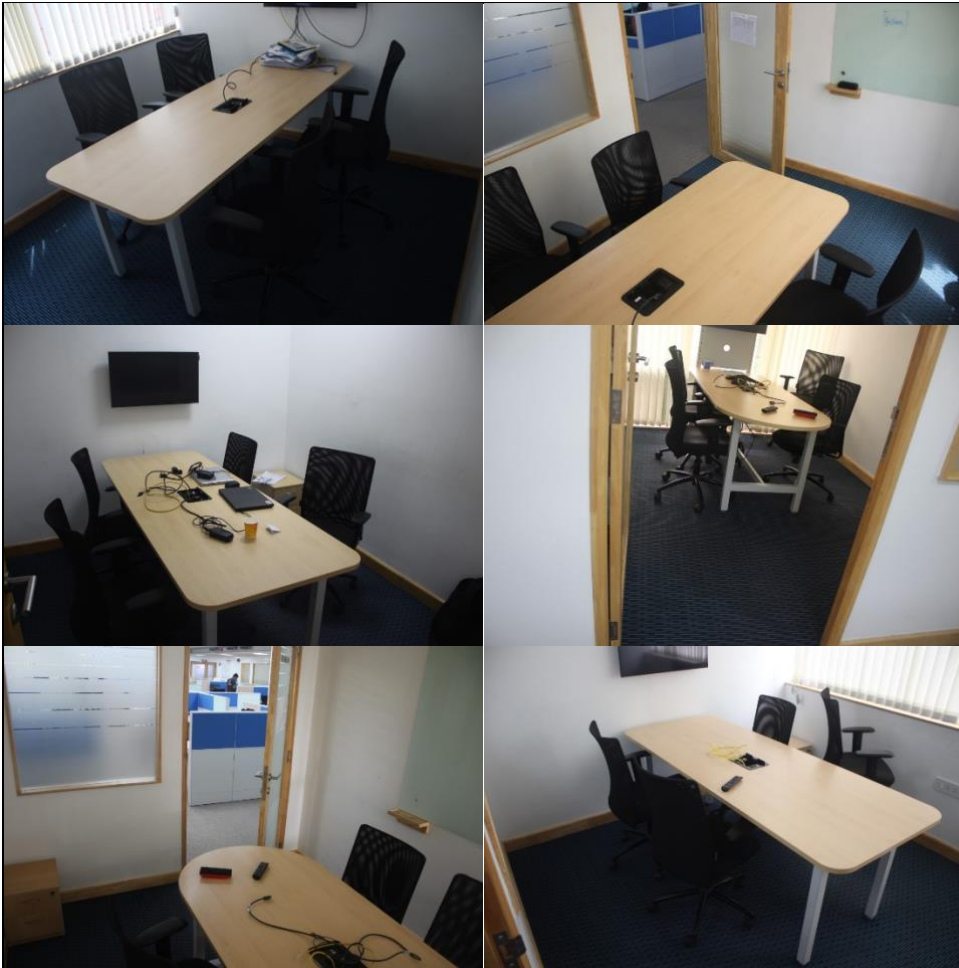

- Almost all the visited meeting rooms have either non-compliant and/or inaccessible chair clearances as marked in the floor plan making these points congested and hard to use for PwDs
- Meeting rooms with a lot of non-compliant and/or inaccessible chair clearances will be too congested and therefore completely inaccessible for certain PwDs
- Whiteboards in all of the meeting rooms are placed at heights that reduces the optimal usage area for certain PwDs
- All the meeting rooms have light switches placed at non-compliant heights with no colour contrast against the background wall making them non-compliant
- A lot of the meeting rooms have marker holders that may act as projection and be unsafe for PwDs as the rooms itself are congested with non-compliant and/or chair clearances especially with the placement point of the marker holders
- Water dispensers, wherever placed, have inaccessible hot water button type making it inaccessible for people with hand impairment

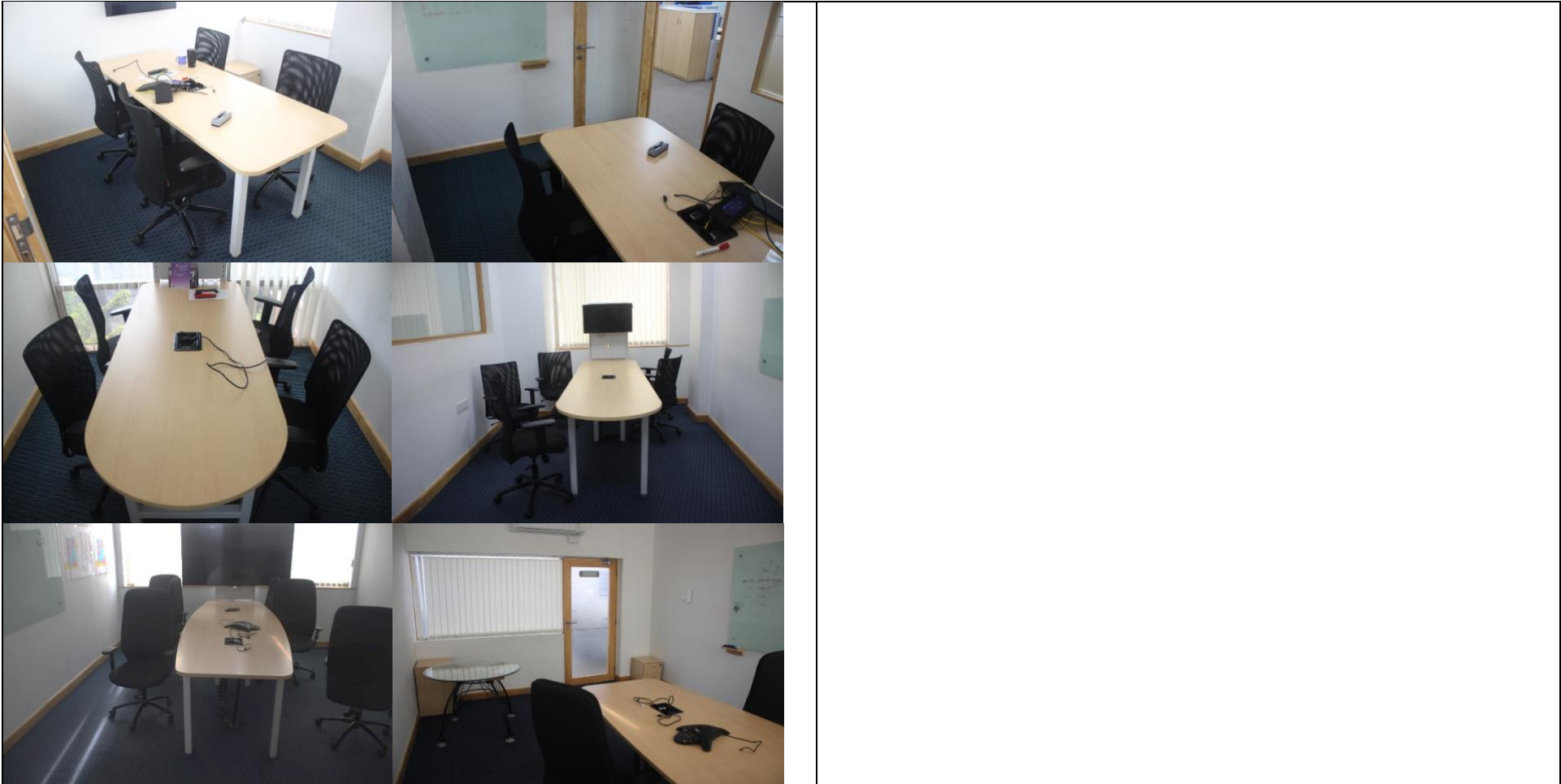



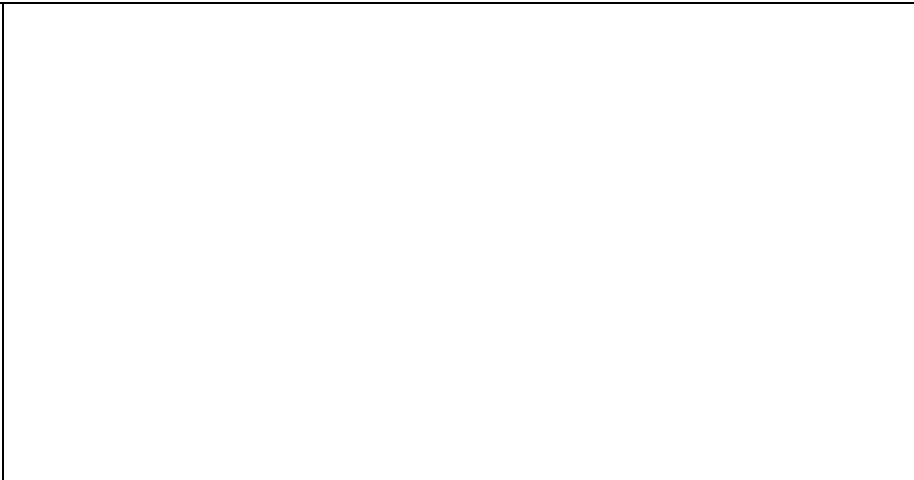

Result: Meeting Rooms are Non-Compliant and Partially Inaccessible

IT HELP DESK

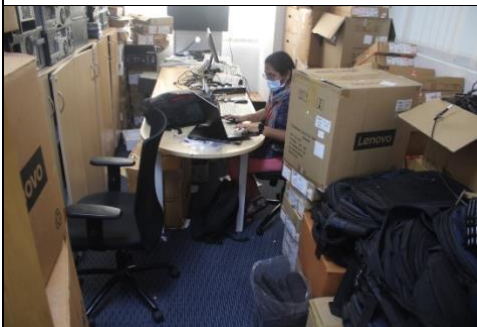

- The IT Helpdesk entry door has high door tension, no pull side door clearance, non-compliant door width, non-compliant handle height and signage placed at non-compliant height with no provisions for braille and tactile making this entry non-compliant and inaccessible for PwDs
- The IT helpdesk room is highly congested with lot of materials stored inside making this room inaccessible and unsafe for most PwDs
- The IT helpdesk room table has inaccessible chair clearances which would make it hard for a lot of PwDs to work here

Result: IT Help Desk is Non-Compliant and Inaccessible

PANTRIES



- The third floor pantry entry door has high door tension, non-compliant door width, inaccessible pull side door clearance, handles placed at non-compliant and inaccessible heights, inaccessible vision panel, ledge at the entry door and signage placed at non-compliant heights with no provisions for braille and tactile making this entry non-compliant and inaccessible
- All the pantries have hand sinks that are counter-mount and are inaccessible for wheelchair users as there is no knee clearance under the sink and at heights that makes them hard to use for people with dwarfism
- The tissue paper dispensers and the soap dispensers are placed at inaccessible heights and/or points making them inaccessible and non-compliant for certain PwDs
- All the coffee machines and microwaves in place do not have provisions for braille and tactile to support people with visual impairment making them non-compliant and inaccessible for people with visual impairment
- The tuck shop in the first floor does not have an accessible cash counter with knee clearance as well as an accessible food takeaway counter in case of self-service and the existing counter is at an inaccessible height
- There is no braille menu for the tuck shop as required by compliance
- All the water dispensers have an inaccessible hot water button type that will be inaccessible for people with hand impairment to use it
- All the water dispensers taps are at non-complaint heights
- Loose mats placed in the ground and second floor pantries are unsafe for PwDs and are non-compliant
- The ground, first and second floor pantries do not have any identification signage in place with provisions for braille and tactile making navigation challenging for PwDs and non-compliant

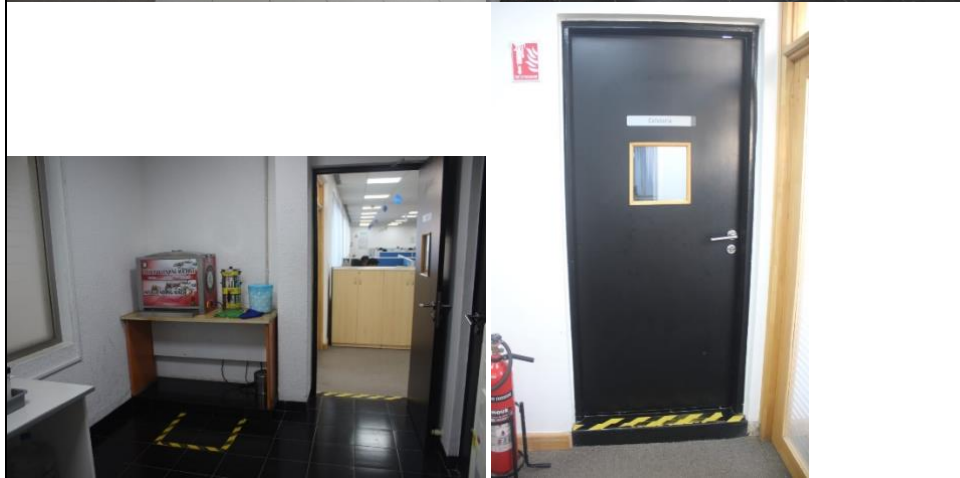

- All the pantries have slippery floors that can be unsafe for PwDs and are non-compliant

Result: Pantries are Non-Compliant and Partially Inaccessible

VENDING MACHINE

- The pickup point of the vending machine is at inaccessible height and the control panel is at a non-compliant height

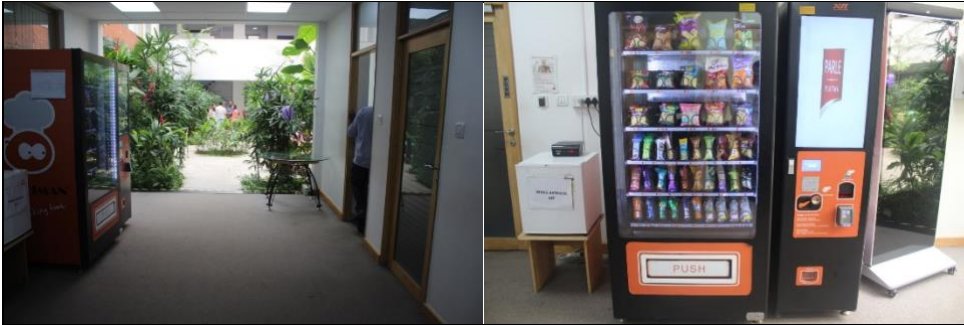

- The vending machine control panel does not have braille/tactile labelling method and/or audio provisions for identification of items in the vending machine

Result: Vending Machine is Non-Compliant and Partially Inaccessible

COURTYARD & BALCONIES



- All the balcony doors are at step levels making the balconies hard to access for wheelchair users
- The first floor balcony door has high door tension, inaccessible door width, handles placed at inaccessible heights with no contrast against the door frame, and door that does not contrast strongly against the background glass wall panel making this entry non-compliant and inaccessible for PwDs
- The second floor balcony door has non-compliant door width, handles placed at inaccessible heights with no contrast against the door frame, and door that does not contrast strongly against the background glass wall panel making this entry non-compliant and inaccessible for PwDs
- The second floor balcony has a step level in the balcony area that is left unmarked making it unsafe for PwDs and harder to use for certain PwDs
- The third floor balcony with a single door for access has an entry door with high door tension, non-compliant door width, inaccessible handle height and no push side door clearance making this entry non-compliant and inaccessible for PwDs



- The third floor balcony on the other side has entry doors that have non-compliant door widths, inaccessible handle heights and while one of the doors does not have push side door clearance, the other one doesn't have push and pull side door clearances making both these entries non-compliant and inaccessible for PwDs
- None of the balcony doors have accessibly placed signage with provisions for braille and tactile making navigation here challenging for PwDs and non-compliant
- The ground floor courtyard access is via steps which makes navigating through it inaccessible for wheelchair users
- The ground floor courtyard pathway has inaccessible points as marked in the floor plan in the centre of the navigation route which makes it hard to use for most PwDs and non-compliant



Result: Courtyard & Balconies are Non-Compliant and Partially Inaccessible

CANTEEN



- The route to the canteen from the office building has uneven flooring, level differences/step level at certain places including the footpath to the road access which is missing kerb ramps making this route inaccessible for certain PwDs and unsafe for others and non-compliant
- The canteen can only be accessed via multiple flights of steps without an alternative accessible route for wheelchair users making this building and facility inaccessible and non-compliant
- The flight of steps leading to the canteen floor do not have colour contrast markings on the edge of the step treads, have handrails at non-compliant heights without any handrail extensions and the last flight of steps have non-compliant width making this route non-compliant
- Loose mats placed near the staircase, entry doors and inside the canteen can be unsafe for PwDs and are non-compliant



- The canteen entry door has no pull side door clearance, handles placed at non-compliant heights with no contrast against the background door panel, doors that do not stand out against rest of the glass panels and no signage with provisions for braille and tactile making this entry non-compliant and inaccessible for PwDs
- The canteen floor can become slippery in the presence of water making this flooring unsafe for PwDs and non-compliant
- The microwave is placed at a non-compliant height and depth and the microwave control panel do not have provisions for braille and tactile to support people with visual impairment making it inaccessible and non-compliant for PwDs
- There is no braille menu for the tuck shop as required by compliance
- The existing food counter setups are at non-compliant heights which will make it difficult for certain PwDs to access and use
- The hand wash in the canteen is counter-mounted and will be inaccessible for wheelchair users as there is no knee clearance under the sink that makes it hard to use for people with dwarfism
- There are no accessible directional signage in the canteen directing one towards the different facilities with provisions for braille and tactile making navigation inaccessible for people with visual impairment

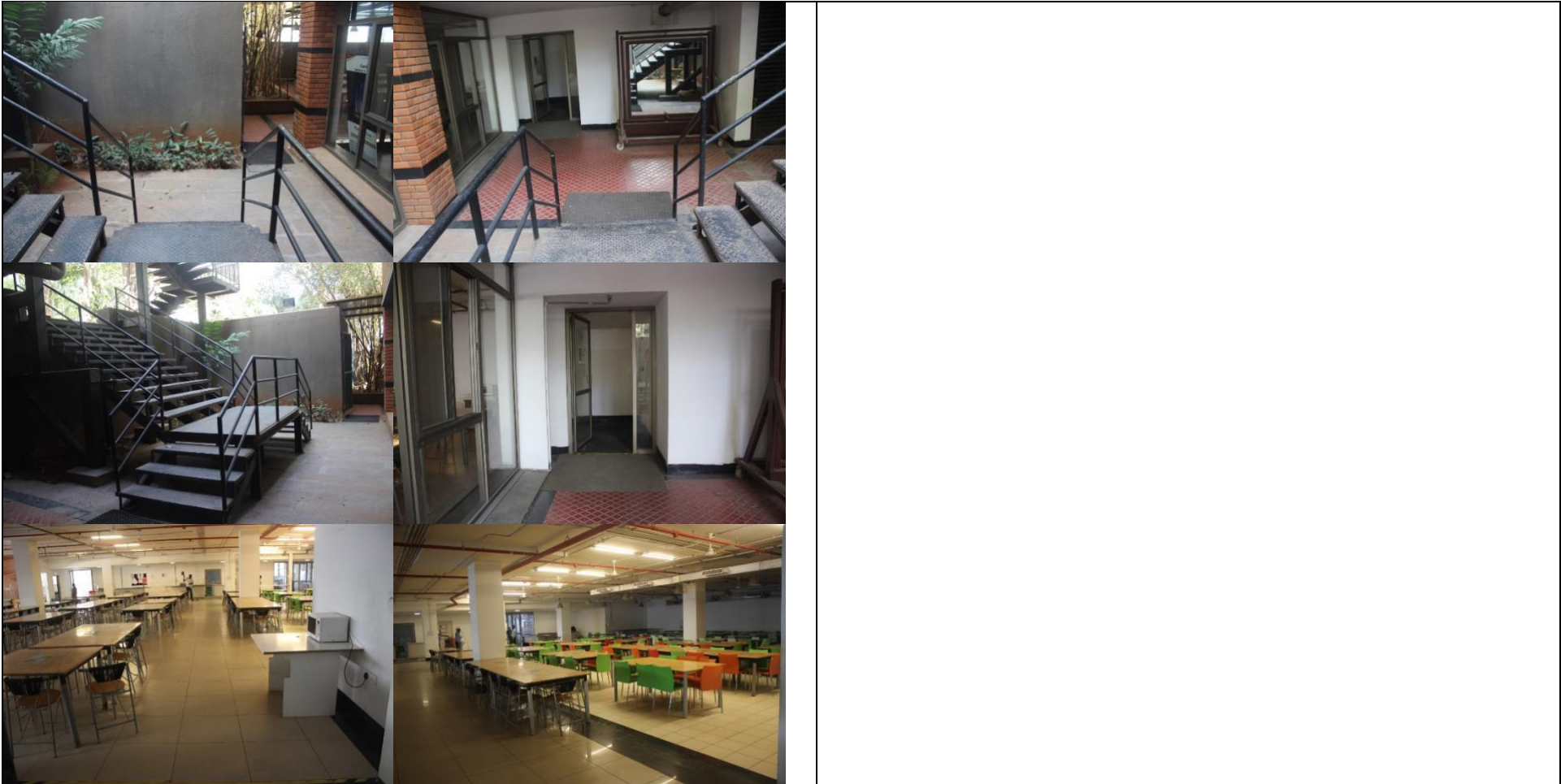



Result: Canteen is Non-Complaint and Partially Inaccessible

PARKING



- There are no accessible two wheeler parking spots marked and allocated for both PwD visitors' and employees which makes it non-compliant and inaccessible
- The marked accessible four wheeler parking slot has non-complaint dimensions, markings including the universal accessibility symbol, no deboarding aisle, and no signage in placed as required by compliance making this slot inaccessible for PwDs to access and use
- The four wheeler parking does not have the required two accessible parking slots for its' number of four wheeler parking slots making this facility non-compliant and inaccessible for PwDs
- There are no directional and identification signage guiding people out of the parking to the building entrance
- The ramp connecting the parking to the building entrance has inaccessible gradient, missing mid-landings, no edge protection, no continuously running dual level handrails at appropriate heights with handrail extensions and no signage identifying this facility for use making this ramp inaccessible and non-compliant for PwDs
- The pathway from the parking to the building entrance has uneven surface which can be unsafe for PwDs and is non-compliant



Result: Parking is Non-Compliant and Inaccessible

STORES, AHU'S & OTHER MAINTENANCE & RESTRICTED AREAS

- All the storage rooms are inaccessible for PwDs because of the style of stacking, space around for navigation with materials inside and lack of accessible information labelling method
- Most of the storage rooms have entry doors with high door tension, non-compliant door widths, handles placed at non-compliant heights, non-compliant vision panel and signage placed at non-compliant and/or inaccessible heights with no provisions for braille and tactile making this entry non-compliant and inaccessible for PwDs
- All other restricted areas are unsafe and dangerous for PwDs and have been considered as restricted entry areas
- All the restricted entry areas like the AHUs, electrical rooms, etc, do not have accessible format signage marking them as restricted entry and some of them have handles placed at inaccessible heights, inaccessible vision panels and inaccessible door clearances that anyways makes it hard for PwDs to enter these spaces

Result: Stores, AHUs & Other Maintenance & Restricted Areas are Non-Compliant and Inaccessible

SECTION D – EMERGENCY EVACUATION FACILITIES

EMERGENCY EVACUATION MAPS, SIGNAGE, FIRE ALARMS, OTHER EQUIPMENTS & PROTOCOLS



- All the emergency evacuation maps are placed at non-compliant and inaccessible heights, have low colour contrast making them hard to read, have highly reflective surfaces and do not have provisions for braille and tactile making them non-compliant and inaccessible for PwDs
- Some of the emergency evacuation maps are blocked by items placed in front of them like printers, etc. that will make them hard to access and read for people with certain disabilities
- Most of the emergency exit and directional signage are placed at inaccessible heights with no provisions for braille and tactile making them non-compliant and inaccessible for people with visual impairment
- The ERT member detail signage does not have an accessible alternative with braille and tactile and/or audio out options to support people with visual impairment
- All the fire alarms and the PTRs are placed at non-compliant heights with no provisions for braille and tactile making them non-compliant and inaccessible for PwDs
- All the first aid kits are placed at inaccessible heights and some of them have fire extinguishers placed in front of them obstructing access to them making them non-compliant and inaccessible for PwDs
- One of the first aid kits placed along the passage route may act as projection and can be unsafe for PwDs and is non-compliant
- There are no blinkers in the restrooms to ensure the safety of people with hearing impairment
- There are no emergency evacuation protocols for PwDs in place



- There are no PwD specific rescue assistance areas in the floor with the required aid and structural compliance
- The emergency call button in the lift is placed at an inaccessible height with no provisions for braille and tactile making them non-compliant and inaccessible for certain PwDs during an emergency



Result: Emergency Evacuation Maps, Signage, Fire Alarms, Other Equipment & Protocols are Non-Compliant and Inaccessible

EMERGENCY ESCAPE EXITS, ROUTES & STAIRCASES

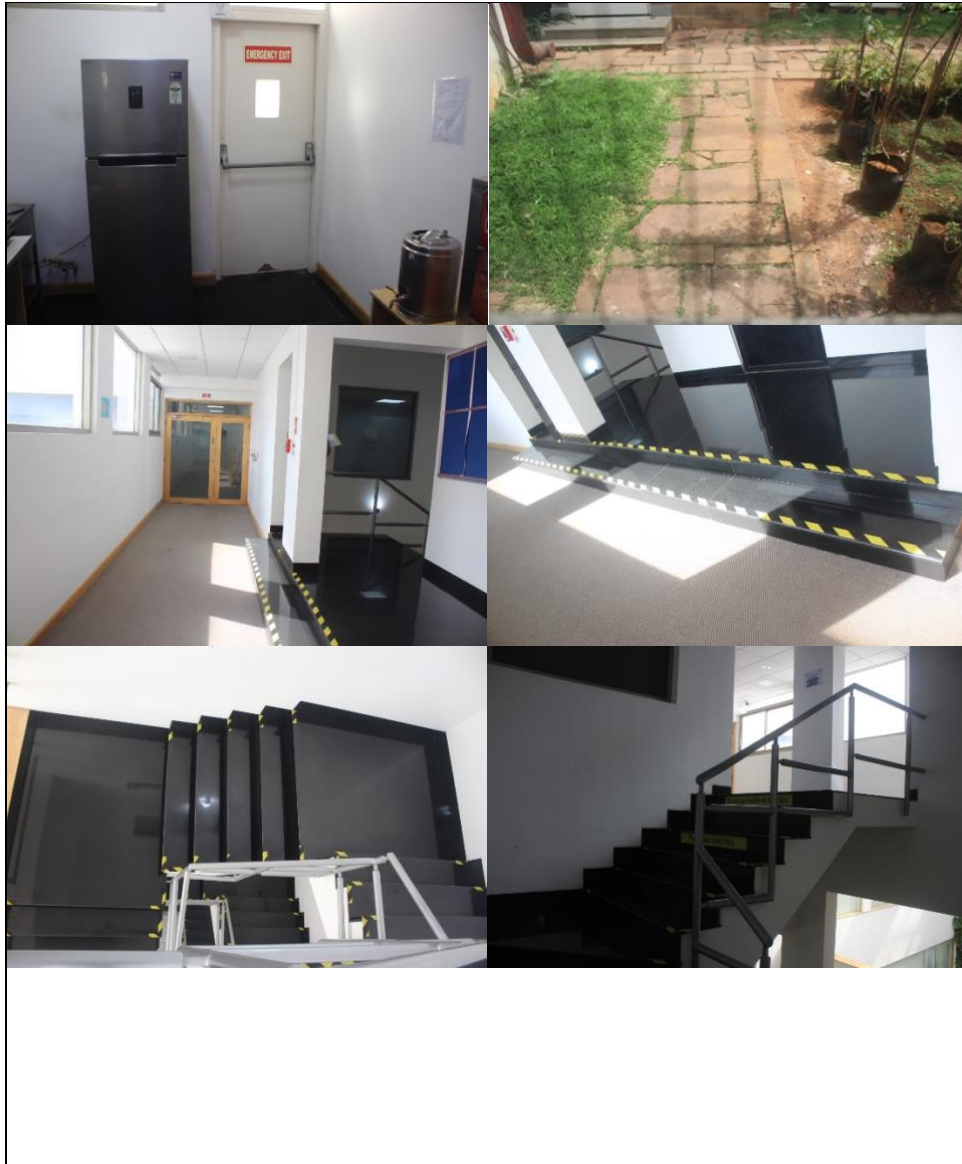

- All the floors have emergency evacuation routes in front of the toilet block areas with non-compliant widths as marked in the floor plans
- Some of the emergency evacuation routes around the first and third floors have non-compliant path widths as marked in the floor plans which will make accessing the emergency exits hard for PwDs from those points/areas
- Some of the emergency evacuation routes around the third floors have inaccessible path widths as marked in the floor plans which will make it inaccessible for PwDs seated around these areas to evacuate safely and on time
- At some parts of the emergency evacuation routes in the third floor there is a dustbin, fire extinguisher and storage units along the route compromising the path widths and making them non-compliant and inaccessible
- If the courtyard is considered for and used as an emergency evacuation route then most of it has non-compliant widths and parts of it has inaccessible widths as marked in the floor plan making navigation through this route non-compliant and hard for certain PwDs
- If the courtyard is considered for and used as an emergency evacuation route then it is inaccessible for wheelchair users as it requires step access
- The ground floor emergency exit door has signage placed at an inaccessible height with no provisions for braille and tactile making this non-compliant and inaccessible
- The ground floor emergency exit door has non-compliant door width, handle placed at a non-compliant height, and vision panel placed at an inaccessible height making this exit door non-compliant and inaccessible for PwDs
- The ground floor emergency exit door has a step at the exit point without any clear landing area after the door which can be unsafe for certain PwDs especially during an emergency evacuation

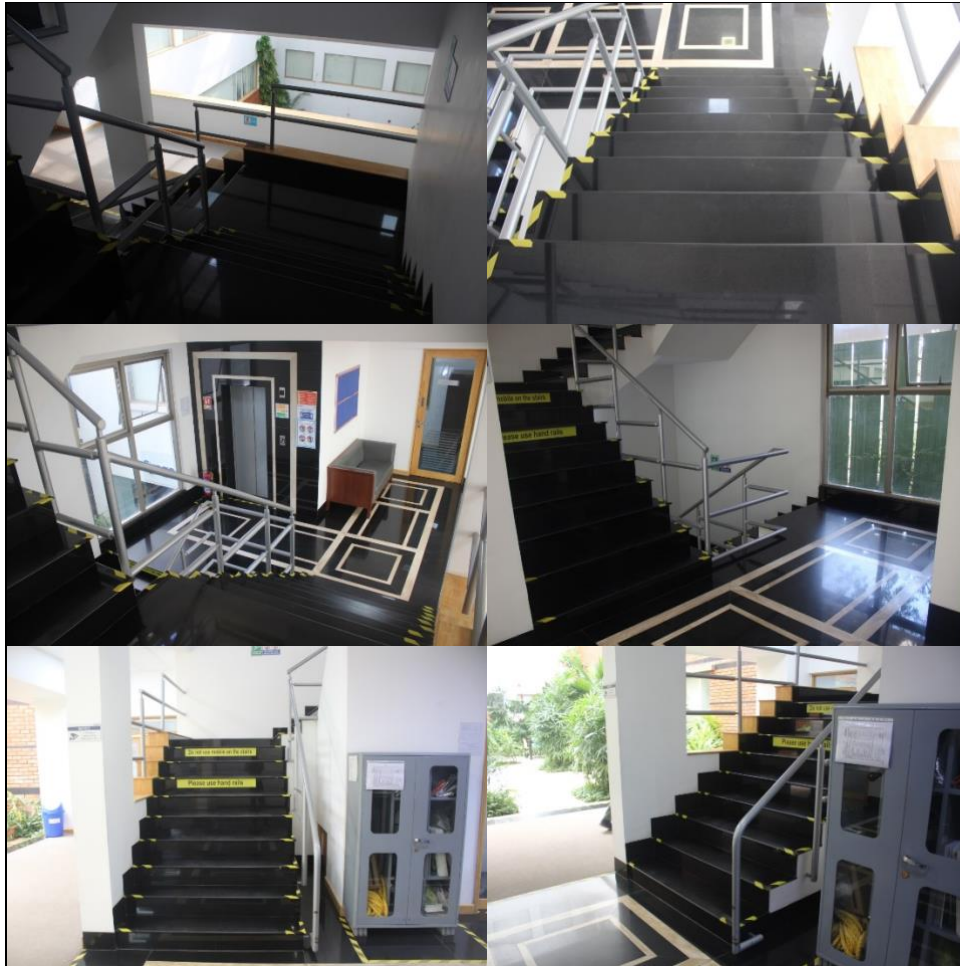

- The path leading away from the building after the ground floor emergency exit door has uneven surface making this exit route inaccessible and unsafe for PwDs
- There are no accessible directional signage leading all the way from the building emergency exits to the safe assembly area which will make it difficult for certain PwDs to safely evacuate during an emergency
- There are no floor identification signage in both the staircases' floor landings with provisions for braille and tactile making them non-compliant and inaccessible for PwDs
- The back emergency exit staircase has inaccessible staircase and mid-landing area widths making this staircase non-compliant and inaccessible for PwDs during an emergency evacuation
- The front emergency exit staircase has non-compliant staircase width in case of adding handrails on the wall side and mid-landing area widths making this staircase non-compliant and inaccessible for PwDs during an emergency evacuation
- Both the emergency exit staircase does not have wall side handrails, the step tread do not have compliant colour marking and the step treads do not have anti-skid provision making this inaccessible and non-compliant for PwDs
- The central running handrails of both the staircases (front and back) do not have handrail extensions at the top and bottom landings and the staircases are missing continuously running wall side handrails with extensions into the landings making both these staircases non-compliant and hard to use for certain PwDs
- The handrails are not completely accessible for people with visual impairment as they are lacking in braille markings for identification of the floor on each landing
- The front staircase handrails on the left side below the beam for the flight that is coming into the landing areas have inaccessible clearance from handrail to the beam making this part of the handrails possibly unsafe for certain PwDs and the head clearance non-compliant

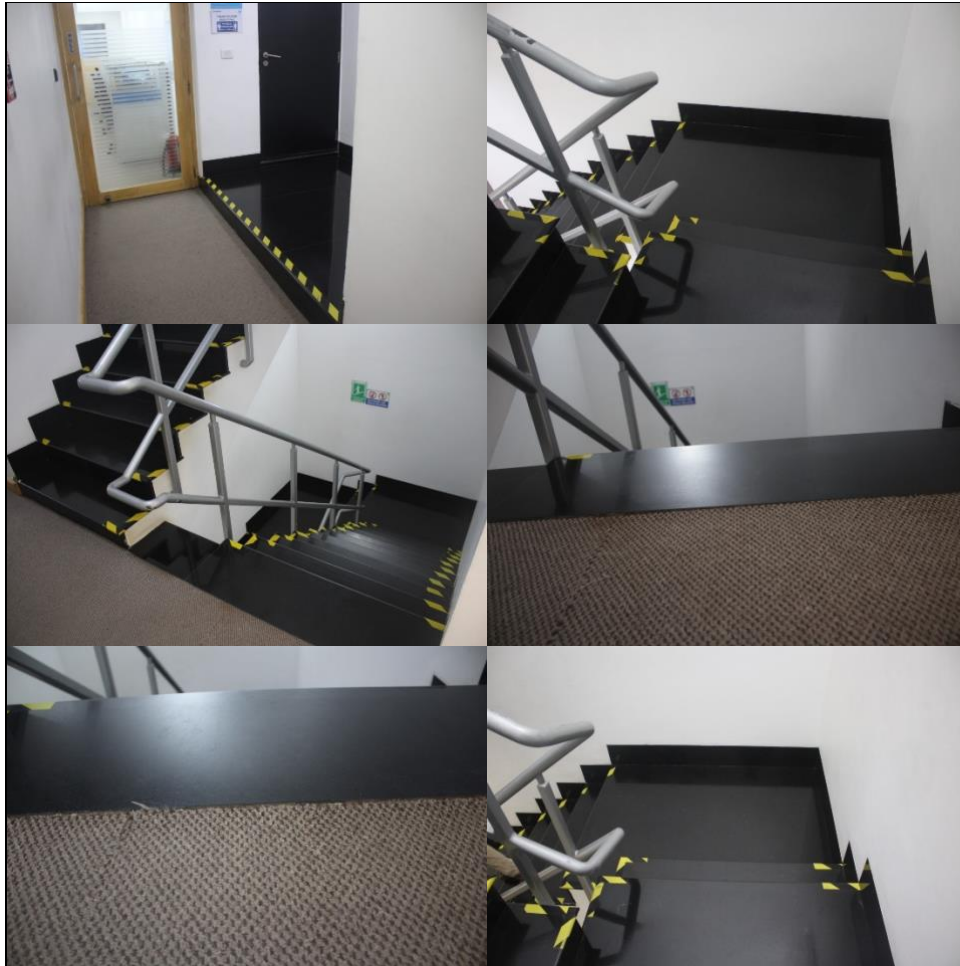

- All the steps in both the staircases have non-compliant colour markings and there are no antiskid provisions for all the step treads making both the staircases non-compliant and unsafe for PwDs
- Access to the front staircase from the third floor office entry has steps to access the staircase which don't have handrails and are missing anti-skid provisions for the step treads making them non-compliant
- The back staircase entry from the floor landings have small level differences because of the improperly flushed carpeted floors at certain points which may be unsafe for certain PwDs

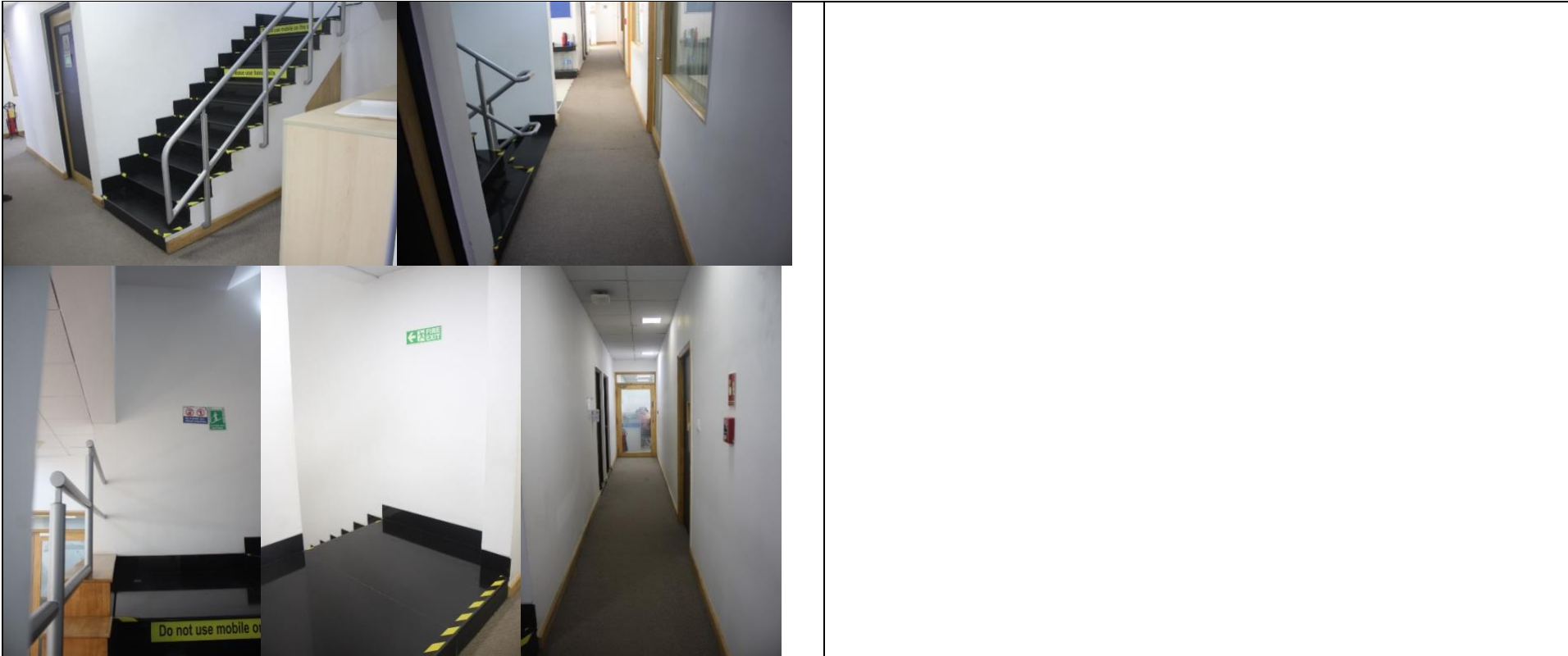

Result: Emergency Escape Exits, Routes & Staircases are Non-Compliant and Inaccessible

NOTE:

1. **VI ACCESSIBILITY:** The entire office is inaccessible for people with visual impairment, as all the work facilities do not have tactile guiding solutions, braille and tactile signage and other assisting devices required to work

SECTION 4: RECOMMENDATIONS TO OVERCOME INACCESSIBILITY

S.NO	RECOMMENDATIONS	PRIORITY (H)IGH & (L)OW	COST (H)IGH, (M)EDIUM, (L)OW
SINGULAR ITEMS - RECOMMENDATIONS			
1	Tactile Pictographic Map: One map should be placed at the reception sharing the floor's layout for directional and orientational purposes	H	M
2	Loop Induction System: To be introduced at the reception, one conference room at least on each floor	H	M
3	PwD Assistance/Navigation Protocols: Internal teams responsible for different facilities and contact centres at different touch points should be trained for assisting PwDs for information and other support including training in sign language	H	M
4	PwD Emergency Evacuation Training: All key staff, support staff and those who are part of buddy system should be trained for the right way to evacuate PwDs	H	M
5	PwD Refuge/Rescue Assistance Areas: Designated spots for refuge areas need to be created for each fire exit of the building at strategic points along with supporting directional signage to facilitate rescue assistance for PwDs in case of emergencies with evacuation protocols that are communicated and trained across all the different teams that need to be involved Refuge areas should be of minimum 750 x 1200 mm in space preferably with easy access to the emergency exits and staircases without blocking the escape routes, cordoned off from the rest of the floor by a smoke barrier having minimum fire resistance rating of 1 hour designed to minimize intrusion of smoke and with a two-way communication system and refuge area signage clearly displayed both on the floor as well as on the wall (1 refuge area for every 200 persons)	H	H

6	Fire Evacuation Chair: A fire evacuation chair needs to be introduced in the office floor to support evacuation of PwDs as and when required	H	H
RECURRING ITEMS (For Multiple Areas) - RECOMMENDATIONS			
1	Vision Impairment Solutions - Tactile guiding solutions and braille and tactile signage needs to be introduced throughout the office floor to make it compliant and accessible for people with visual impairment	H	H
2	Signage: Appropriate Universal Identification, Directional, and Emergency Signage with appropriate colour contrast should be introduced consistently throughout the office for navigation and identification of key facilities and services, accessible facilities, and for emergency evacuation with braille and tactile. Signage placement heights for the specific mentioned signage pieces should be corrected along with format, contrast against background, matt finish and missing signage should be added. Braille and Tactile markers, audio provisions and maps should be added wherever required as identified like for storage units, fire alarms etc	H	H
3	Doors: All the non-compliant style door handles and locks should be replaced with accessible handles and locks that are easy to operate with fists and placed at accessible height as shared in Guideline 4 and have high contrast against the background door panel	H	M
4	Doors: All the non-compliant width doors should be replaced with accessible open width of 900 mm and vision panels corrected wherever required to start from 800 mm and go till 1500 mm	H	M
5	Doors: All doors as specified, should have a door clearance of 300 mm on the push side and 600 - 650 mm on the pull side barring men's and women's toilets as well as the emergency exit doors where it should be 450 mm on the push and pull side	H	H
6	Doors: Door tension needs to be reduced to 20 Newton by reducing the door closer tension for all doors	H	L

7	Doors: All high usage doors as specified, should have kick plates of 300 – 400 mm height placed on both sides to protect from wheelchairs and doors should have high contrast against the background wall	H	L
8	Glass Walls & Doors: For glass walls and doors, colour bands of minimum 75 mm thickness should be added at two levels of 800 mm and 1500 mm	H	L
9	Mats: For areas where mats are essential, create recessed areas for mats to ensure sunken mats they are at floor level and don't cause tripping	H	M
10	Mats: Where mats are unnecessary remove	H	-
11	Ramps: The ramps should be made accessible by correcting the gradient to 1:12 or 1:15 and the width should be made 1500 or 1800 mm between the handrails with landing of 1500 x 1500 mm on both ends with an edge protection up till 50 mm from the floor level on the sides of the ramp and mid-landings added as required by compliance	H	M
12	Step Treads: All step treads whether at entrances or in the staircases as marked in the barriers section, should have colour contrasting marking tape at the edge of the tread which is also anti-slip as shared in Guideline 6	H	M
13	Steps and Ramps: All steps and ramps should have handrails on both sides next to them extending 300 mm out on both sides with a diameter of 38-45 mm and the ramp should have dual level handrails at 950 mm top height and 750 mm lower level handrail top height while for staircases handrail height should not exceed 950 mm	H	M
14	Ledges and Level Differences: All ledges, level differences and uneven broken paths that act as ledges in the circulation path and to access various facilities should be smoothed out so a wheelchair can easily pass through the space	H	-
15	Staircases: Handrails may have braille embedded to indicate floor level	H	L
16	Staircases: Handrails should have continuous handrails on both sides at 900-950 mm height with handrail extensions that curve towards the end for 300 mm after the last step indicating the floor landing	H	M

17	Staircases: Staircase width should be a minimum of 1200 mm and 1500 mm between handrails in case of an emergency exit staircase and the landings should be proportionally matched and minimum 1200 mm deep and riser heights should not exceed 150 mm as per compliance	H	M
18	Staircases: Staircases should have handrails that contrast against the background wall as per compliance	H	M
19	Lifts: The heights of lift call buttons, control panels and handrails to be at a wheelchair compliant height as shared in Guideline 2 and handrails added on all three sides	H	H
20	Lift and Lift Lobby: Braille and tactile should be added to the lift call buttons and the control panels	H	L
21	Lift and Lift Lobby: Audio out for the lifts to be activated	H	-
22	PwD Restroom: Add accessible signage, toilet layout, required supportive aids, fixtures and accessories in the PwD Restroom as shared in Guideline 1 and pointed in the barriers	H	H
23	Men's Restroom: Introduce stand-up urinal support for one urinal designated accessible urinal which is placed at 430 mm from the floor (bottom end of urinal) in each men's restroom	H	M
24	Men's & Women's Restrooms: Introduce one WC cubicle that is at least 35 inches wide between the grab bars and 900 mm clear space in front of the WC, with standard accessible outward and inward opening doors of minimum 900 mm open door width and accessible handles, with L-shape grab bars on either side of the WC, and health faucet and toilet paper placed next to the WC on the walls for the ambulatory disabled	H	M
25	Hand Wash: Introduce a hand wash setup compliant for wheelchair users with soap and paper towel dispensers at accessible heights as shared in Guideline 3 in the canteens	H	M
26	Flooring: All areas where flooring has high reflective index should be replaced with flooring that is less glossy	L	-

27	Flooring: All areas where lack of anti-slip flooring is mentioned should be made anti-slip by changing the tiles or having other form of anti-slip treatment to the tiles or flooring	H	M
28	Counters: Inaccessible counters like the reception counters, security sign-in, food counter and the tuck shop cash counter should be replaced with wheelchair accessible counters as shared in Guideline 5 and have knee clearance of at least 480 mm below the counter	H	H
29	Coffee Machines & Microwaves: A braille reading option should be added to all machines for people with visual impairment and the coffee machine panel heights should be as shared in Guideline 5	H	L
30	Canteen: Braille menus should be introduced for the tuck shop counter	H	M
31	Drinking Water Setups: Use Automated drinking water setups or ones with lever taps that are accessible at 800 – 1000 mm with minimal depth to reach the drinking water taps	H	L
32	Vending Machine: The vending machine pickup point should be above 400 mm	H	M
33	Hand Sanitizer Setup: Use sensor-based hand sanitisers placed at 1000 mm height FFL	M	L
34	Controls and Light Switches: All switch controls should be placed between 900 to 1100 mm height and contrast against the background walls and panels	H	M
35	Seating Rearrangement: Seating layouts should be rearranged to make inaccessible/non-compliant desks and seating areas accessible	H	-
36	Seating Rearrangement: Table layouts should be rearranged for accessible navigation space and required 1200 mm chair clearance space and tables that are larger than the rooms making the areas non-compliant should be replaced with units that fit into the space	H	-
37	Whiteboards: Whiteboards should be placed starting at 762 mm to increase the optimal usage area to accommodate wheelchair users and people with dwarfism as much as is possible	M	L
38	Power Sockets & Cable Cubbies: Place extension cords or power cubes or side power sockets in meeting rooms and on work desks wherever inaccessible power sockets are there	H	L

39	Printers & Other Machines: Should have an option of audio out for people with visual impairment	H	L
40	Lockers & Storage Units: Introduce braille or tactile stickers as required with an employee with VI and introduce handles with 50 mm grip space	H	M
41	Key Information Items: All key information like the safety and emergency instructions, and other work and notice board information should have a braille and tactile alternate placed next to it or audio option accessible placed next to it	H	M
42	Projections: Remove projections in circulation paths like wall-mounted first aid kit, hand sanitisers, marker holders, etc.,	H	L
43	Items at Inaccessible/Non-Compliant Height: All items marked for inaccessible/non-compliant heights like signage, access card readers, light switches, fire alarms, PTRs, Emergency Phone, Printers, Tissue paper and soap dispensers, etc. should be adjusted to accessible/compliant heights as shared in Guideline 5	H	M
44	Toilets: Blinkers should be introduced in restrooms to support people with hearing impairment in case of an emergency	H	L
45	Emergency Evacuation Maps: The emergency evacuation maps should be in braille and tactile and of the right readable size with contrast for readability	H	M
46	Path Width: Footpath widths should be at least 1500 mm if not 1800 mm and internal routes should be of at least 1200 mm width and for two-way and evacuation routes should be of 1500 mm minimum width with turning space of 1200 mm x 1200 mm or 1500 mm x 1500 mm	H	M
47	Footpaths: All footpaths should have an accessible egress route by means of ramps or kerb ramps with preferable ramp gradient of 1:20 and minimum gradient of 1:10 as shared in Guideline 7	H	M
48	Gratings: Gratings need to be replaced with gratings with less than 10 mm opening	H	H

49	PwD Parking: Add Two-Wheeler and Four-Wheeler parking slots within 30 meters from the lift area and/or building entrance with the universal accessibility symbol on the floor as shared in Guideline 8	H	L

APPENDIX 1: SVADHIN SOLUTIONS | COMPANY PROFILE

Svadhin Solutions provides accessibility solutions to individuals and organizations to help overcome their accessibility barriers in their work and living environments. Our vision is to create barrier-free environments that enhance individuals' independence, quality of life, and contribution towards the society.

Svadhin provides solutions for both upcoming and retrofit buildings by understanding accessibility barriers by designing comprehensive solutions after mapping and analysing the user and their physical environment. We merge years of research and multiple disciplines like anthropometry, ergonomics, human-centred product and space design and occupational therapy. We understand the key stakeholders' needs, thereby integrating best-fit solutions. We have successfully audited and implemented universal design solutions for individuals and institutions including hospitals, hotels, clinics, and corporates.

SVADHIN

BRING IN THE EXPERTS TO ENABLE
ACCESSIBILITY FOR YOUR SPACES!



APPENDIX 2: GUIDELINES FOR ACCESSIBILITY

GUIDELINE 1: PWD RESTROOM

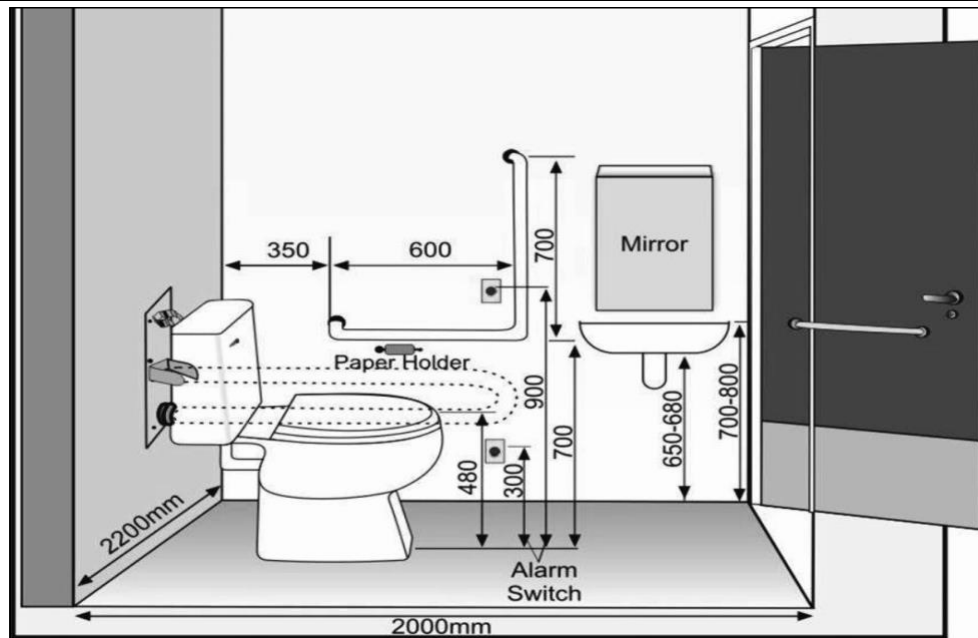

- Support to be present on either sides of the WC to transfer or get in and out of the WC with a transfer space of 900 mm on both or one side at least
- Wall mounted hand sink with arm support should be at 28 inches above the ground
- A stick tap with depth of maximum 12 inches should be used at the hand sink
- A 15 degree tilted mirror should be used above the hand sink starting from 1000 mm from the floor level
- Side flush should be provided for easy access
- There should be a push bar on both sides of the door at a height of 34 inches
- The emergency alarm should be placed at a height of 800 mm and 400 mm

GUIDELINE 2: LIFT AND LIFT LOBBY

		<ul style="list-style-type: none"> ➤ The size of the lift should be 1500 mm by 1500 mm ➤ Door width of the lift should be 900 mm ➤ Control panel and call button heights should be at 1000 mm
--	--	--

GUIDELINE 3: HAND WASH AREA

	<ul style="list-style-type: none"> ➤ The upper end of the wall mounted hand sink should be at 31 inches ➤ The lower end of the wall mounted hand sink should be 26 inches above the ground ➤ Arm support to be provided for the hand sink ➤ The stick tap depth should be not more than 12 inches ➤ A 15 degree tilted mirror should be placed on the wall starting at a height of 1000 mm from the floor
--	--

GUIDELINE 4: DOOR LAYOUT

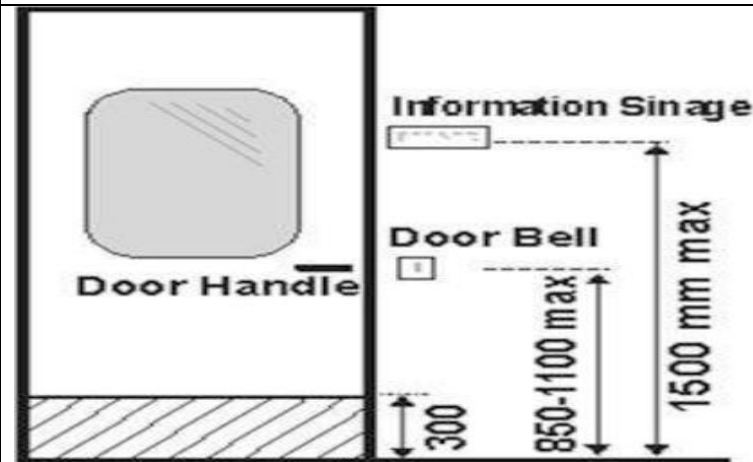

- The door width should be at least 900 mm
- Door handle height should be 1100 mm preferably 1000 mm
- Signage height on door should be 1500 mm
- Access card panel, EDRs, Fire Alarms, and PTRs height should be within 900 mm – 1100 mm

GUIDELINE 5: ACCESSIBLE HEIGHTS & WIDTH

- Light Switches should be at 1000 mm max
- Corridor and Internal Circulation width should be 1500 -1800 mm and minimum of 1200 mm
- Control panels where requirement of hand movement is high should be between 900 mm – 1100 mm and preferably within 1000 mm height like vending machine panels, ATM control buttons, numbered access card panels
- Hand sanitizers, soap dispensers, tissue paper dispensers should have usage point placement at a height of 800 mm – 1000 mm
- Printers top panels should not exceed 1200 mm height for wheelchair users usability
- Shelves and Cabinets should be at a maximum height of 1150 mm and maximum depth of 500 mm
- Signage height for wall signage is 1500 mm and for ceiling hung signage is 1800 mm
- Counters should be at a maximum height of 780 mm with knee clearance of 480 mm on the visitor side

GUIDELINE 6: STEP MARKING

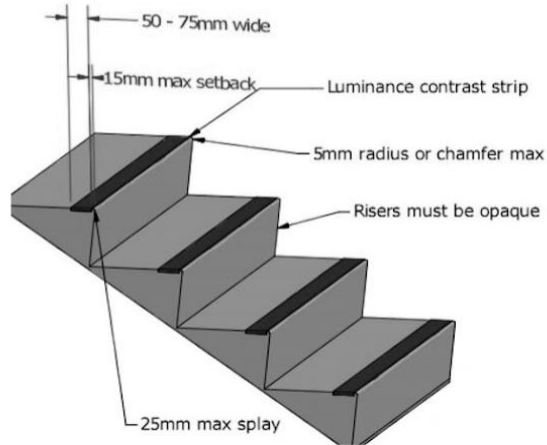

- Each step tread must be color marked with contrasting strips of 2 to 3 inches
- Tread set back should be maximum 15 mm (.59 inches)

GUIDELINE 7: KERB RAMP ON FOOTPATH

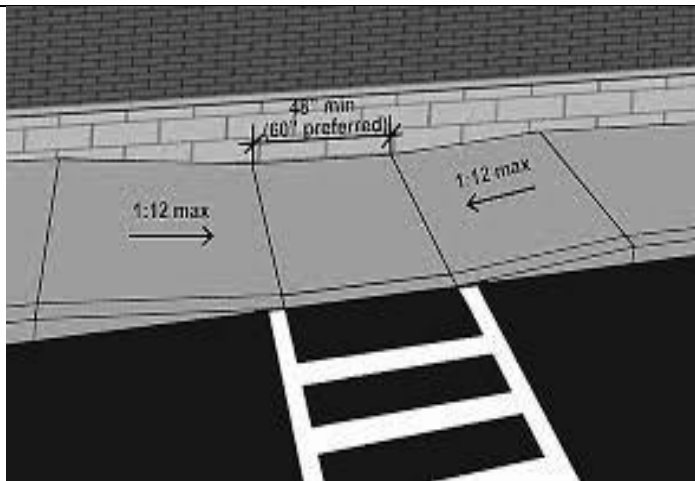

- The footpath/sidewalk should not be more than 150mm high
- The footpath/sidewalk should be atleast 1800mm wide
- The minimum landing area width should be 1200-1500mm wide (1500mm preferable)
- The gradation of the connecting slope should be 1:12

GUIDELINE 8: 4 WHEELER PARKING (Harmonized Guidelines)

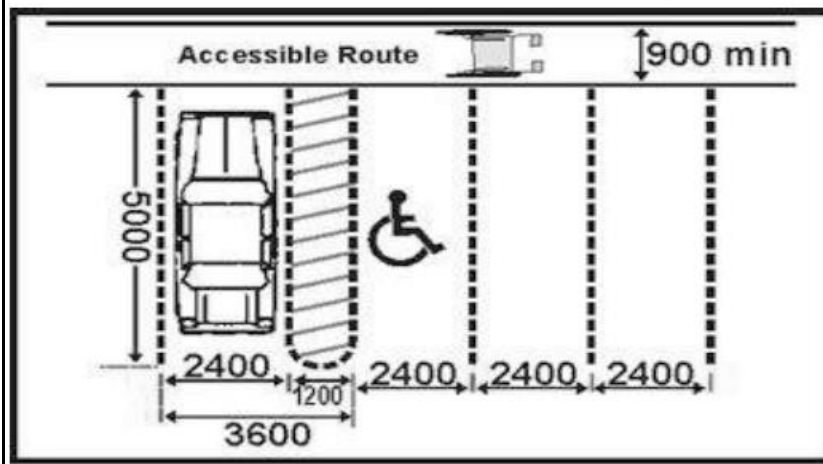

- Universal accessible parking symbol in a square to be marked on the ground of minimum 1000 mm dimensions or 1500 mm
- Parking slot should be within 30 meters from the accessible entrance
- 4 Wheeler parking slot size should be 5000 mm by 3600 mm including the boarding and de-boarding bay with dimensions of 1200 mm by 3600 mm

APPENDIX 3: GLOSSARY OF TERMS

Access Aisle - An accessible pedestrian space between elements, such as parking spaces, seating and desks that provides clearances appropriate for use of the elements.

Accessible - A site, building, facility, or portion thereof that complies with these guidelines and that can be approached, entered and used by all people.

Accessible Signage - Any visual way finding system incorporates architecture, landscape design, lighting, landmarks, and orientation points. Signage is one key element of an effective way finding system and should be accessible to all users including people with disabilities.

Area of Rescue Assistance - An area, which has direct access to an exit, where people who are unable to use stairs may remain temporarily in safety to await further instructions or assistance during emergency evacuation.

Braille Signage - Is a specialist way finding device that incorporates Braille as a primary source of information for people who are vision impaired and maybe aided with raised tactile lettering, maps, or pictorial images.

Braille - The Braille system is a method that is widely used by blind people to read and write.

Circulation Path - An exterior or interior way of passage from one place to another for pedestrians, including walkways, hallways, courtyards, stairways, and stair landings.

Clear Floor Space - The minimum unobstructed floor or ground space required to accommodate a single, stationary wheelchair and occupant.

Color Contrast - The basic guidelines for making effective color choices are based on the hue value of the colors. The most commonly used methods of achieving color contrast incorporate either harmonizing or contrasting color combinations.

Detectable Warning - A standardized surface feature built in or applied to walking surfaces or other elements to warn visually impaired people of hazards on a circulation path.

Disability - is an umbrella term for impairments (WHO, 2004), activity limitations, and participation restrictions, denoting the negative aspects of the interaction between an individual (with a health condition) and that individual's contextual factors (environmental and personal factors). Disability is neither simply a biological nor a social phenomenon but arises from the relationship between health condition and context.

Grab Bars - A bar used to give a steadying or stabilizing assistance to a person engaged in a particular function.

Handrails - A rail used in circulation areas such as corridors, passageways, ramps, and stairways to assist in continuous movement.

Induction loop - An induction or inductive loop is an electromagnetic communication or detection system, which uses a moving magnet to induce an electric current in a nearby wire. Induction loops are used for transmission and reception of communication signals, or for detection of metal objects in metal detectors or vehicle presence indicators. A common modern use for induction loops is to provide hearing assistance to hearing aid users.

International Symbol of Access - Also known as the (International) Wheelchair Symbol, the International Symbol of Access consists square overlaid with a stylized image of a person using a wheelchair. The symbol is often seen where access has been improved, particularly for wheelchair users and other mobility impaired persons. The symbol denotes a barrier free environment, such as steps, to help also older people, parents with prams, and travellers with luggage. The wheelchair symbol is "International" and therefore not accompanied by Braille in any particular language.

Luminosity Contrast - Also known, as tonal contrast is the most important element that assists people with vision impairments to distinguish between two different surfaces.

LRV - Light reflectance value (LRV) is the total quantity of visible light reflected by a surface at all wavelengths and directions when illuminated by a light source.

Lux - Is the standard unit of illumination. It is used as a measure of perceived intensity of light.

Power-Assisted Door - A door used for human passage with a mechanism that helps to open the door, or relieves the opening resistance of a door, upon the activation of a switch or a continued force applied to the door itself.

Ramp - An inclined way connecting one level with another.

Signage - Any room number, name tag, building directory, or similar object containing a printed message and/or symbol. Signage and signs are used synonymously in this document.

Space - A definable area (for example, toilet room, hall, assembly area, entrance, storage, room alcove, courtyard, or lobby).

Tactile - Tactile means information and interpretations derived from the sense of touch. This involves sensory transfer through physical contact of the hands or feet with other surfaces, as well as sensory transfers received by contact with non-physical elements such as pressure, wind and temperature.

Tactile Paving/Tiles - (also called Tactile Ground Surface Indicators) provide a distinctive surface pattern of “strips” and “truncated domes” or cones (which are small domes or cones that have had their tops cut off, or truncated) detectable by long cane or underfoot which are used to guide/alert persons with vision impairments of their approach to facilities, streets and hazardous drop-offs. People who are blind or visually impaired are alerted of impending danger from vehicle impact or a grade change.

Tactile Signs -Tactile signage incorporates raised text or symbols to enable touch reading by people who are blind, and touch enhancement of visual perception for people who are vision impaired.

Tactile Warning Blocks - In order to warn persons with visual impairments of the approaching danger, it is recommended to incorporate Tactile Ground Surface Indicators (TGSI) along the approach path to unavoidable obstacles and hazards. These tactile warning blocks are recognized internationally as a sign of approaching hazards.

Transfer Device - Equipment designed to facilitate the transfer of a person from a wheelchair or other mobility device to and from another seat.

Treads and Risers - On any given flight of stairs, all steps shall have uniform riser heights and uniform tread widths. Stair treads shall be no less than 11 in (280 mm) wide, measured from riser to riser (see Fig. 18(a)). Open risers are not permitted.

Universal Design - Defined as “the design of products and environments to be usable by all people, to the greatest extent possible, without the need for adaptation or specialized design”.